

JVC

SERVICE MANUAL

MICRO COMPONENT SYSTEM

UX-P3

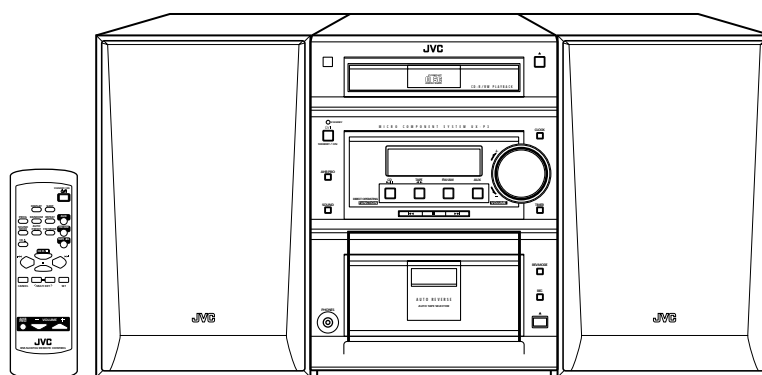

SP-UXP3

CA-UXP3

SP-UXP3

COMPACT
disc
DIGITAL AUDIO

Area Suffix

UB Hong Kong
 UP Korea
 US Singapore
 UW South Africa
 UY Argentina

Contents

Safety precautions	1-2	Maintenance of laser pickup	1-19
Preventing static electricity	1-4	Replacement of laser pickup	1-19
Important for laser products	1-6	Description of major ICs	1-20
Disassembly method	1-7	Internal connection of display	1-39
Main adjustment	1-14		
Flow of functional operation until TOC read (CD)	1-18		

Safety Precautions

1. This design of this product contains special hardware and many circuits and components specially for safety purposes. For continued protection, no changes should be made to the original design unless authorized in writing by the manufacturer. Replacement parts must be identical to those used in the original circuits. Services should be performed by qualified personnel only.
2. Alterations of the design or circuitry of the product should not be made. Any design alterations of the product should not be made. Any design alterations or additions will void the manufacturer's warranty and will further relieve the manufacture of responsibility for personal injury or property damage resulting therefrom.
3. Many electrical and mechanical parts in the products have special safety-related characteristics. These characteristics are often not evident from visual inspection nor can the protection afforded by them necessarily be obtained by using replacement components rated for higher voltage, wattage, etc. Replacement parts which have these special safety characteristics are identified in the Parts List of Service Manual. Electrical components having such features are identified by shading on the schematics and by (\triangle) on the Parts List in the Service Manual. The use of a substitute replacement which does not have the same safety characteristics as the recommended replacement parts shown in the Parts List of Service Manual may create shock, fire, or other hazards.
4. The leads in the products are routed and dressed with ties, clamps, tubings, barriers and the like to be separated from live parts, high temperature parts, moving parts and/or sharp edges for the prevention of electric shock and fire hazard. When service is required, the original lead routing and dress should be observed, and it should be confirmed that they have been returned to normal, after re-assembling.
5. Leakage current check (Electrical shock hazard testing)
After re-assembling the product, always perform an isolation check on the exposed metal parts of the product (antenna terminals, knobs, metal cabinet, screw heads, headphone jack, control shafts, etc.) to be sure the product is safe to operate without danger of electrical shock.
Do not use a line isolation transformer during this check.

- Plug the AC line cord directly into the AC outlet. Using a "Leakage Current Tester", measure the leakage current from each exposed metal parts of the cabinet, particularly any exposed metal part having a return path to the chassis, to a known good earth ground. Any leakage current must not exceed 0.5mA AC (r.m.s.).

- Alternate check method

Plug the AC line cord directly into the AC outlet. Use an AC voltmeter having, 1,000 ohms per volt or more sensitivity in the following manner. Connect a $1,500\ \Omega$ 10W resistor paralleled by a $0.15\ \mu\text{F}$ AC-type capacitor between an exposed metal part and a known good earth ground. Measure the AC voltage across the resistor with the AC voltmeter.

Move the resistor connection to each exposed metal part, particularly any exposed metal part having a return path to the chassis, and measure the AC voltage across the resistor. Now, reverse the plug in the AC outlet and repeat each measurement. Voltage measured any must not exceed 0.75 V AC (r.m.s.). This corresponds to 0.5 mA AC (r.m.s.).

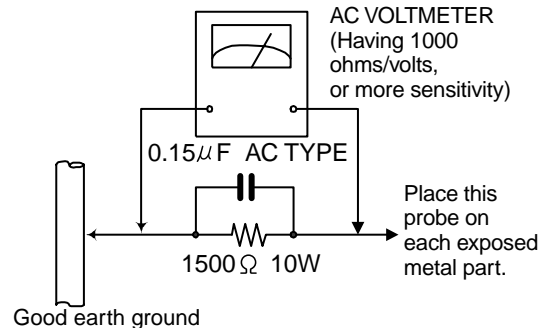

Warning

1. This equipment has been designed and manufactured to meet international safety standards.
2. It is the legal responsibility of the repairer to ensure that these safety standards are maintained.
3. Repairs must be made in accordance with the relevant safety standards.
4. It is essential that safety critical components are replaced by approved parts.
5. If mains voltage selector is provided, check setting for local voltage.

CAUTION

Burrs formed during molding may be left over on some parts of the chassis. Therefore, pay attention to such burrs in the case of preforming repair of this system.

In regard with component parts appearing on the silk-screen printed side (parts side) of the PWB diagrams, the parts that are printed over with black such as the resistor (■), diode (▬) and ICP (●) or identified by the (\triangle) mark nearby are critical for safety.

When replacing them, be sure to use the parts of the same type and rating as specified by the manufacturer. (Except the J and C version)

Safety precautions (U.K only)

1. This design of this product contains special hardware and many circuits and components specially for safety purposes. For continued protection, no changes should be made to the original design unless authorized in writing by the manufacturer. Replacement parts must be identical to those used in the original circuits.
2. Any unauthorised design alterations or additions will void the manufacturer's guarantee ; furthermore the manufacturer cannot accept responsibility for personal injury or property damage resulting therefrom.
3. Essential safety critical components are identified by () on the Parts List and by shading on the schematics, and must never be replaced by parts other than those listed in the manual. Please note however that many electrical and mechanical parts in the product have special safety related characteristics. These characteristics are often not evident from visual inspection. Parts other than specified by the manufacturer may not have the same safety characteristics as the recommended replacement parts shown in the Parts List of the Service Manual and may create shock, fire, or other hazards.
4. The leads in the products are routed and dressed with ties, clamps, tubings, barriers and the like to be separated from live parts, high temperature parts, moving parts and/or sharp edges for the prevention of electric shock and fire hazard. When service is required, the original lead routing and dress should be observed, and it should be confirmed that they have been returned to normal, after re-assembling.

Warning

1. Service should be performed by qualified personnel only.
2. This equipment has been designed and manufactured to meet international safety standards.
3. It is the legal responsibility of the repairer to ensure that these safety standards are maintained.
4. Repairs must be made in accordance with the relevant safety standards.
5. It is essential that safety critical components are replaced by approved parts.
6. If mains voltage selector is provided, check setting for local voltage.

 **CAUTION** Burrs formed during molding may be left over on some parts of the chassis. Therefore, pay attention to such burrs in the case of performing repair of this system.

Preventing static electricity

Electrostatic discharge (ESD), which occurs when static electricity stored in the body, fabric, etc. is discharged, can destroy the laser diode in the traverse unit (optical pickup). Take care to prevent this when performing repairs.

1.1. Grounding to prevent damage by static electricity

Static electricity in the work area can destroy the optical pickup (laser diode) in devices such as DVD players. Be careful to use proper grounding in the area where repairs are being performed.

1.1.1. Ground the workbench

1. Ground the workbench by laying conductive material (such as a conductive sheet) or an iron plate over it before placing the traverse unit (optical pickup) on it.

1.1.2. Ground yourself

1. Use an anti-static wrist strap to release any static electricity built up in your body.

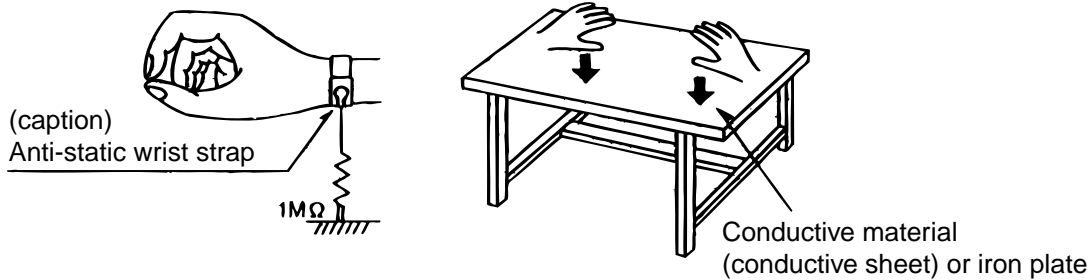

1.1.3. Handling the optical pickup

1. In order to maintain quality during transport and before installation, both sides of the laser diode on the replacement optical pickup are shorted. After replacement, return the shorted parts to their original condition. (Refer to the text.)
2. Do not use a tester to check the condition of the laser diode in the optical pickup. The tester's internal power source can easily destroy the laser diode.

1.2. Handling the traverse unit (optical pickup)

1. Do not subject the traverse unit (optical pickup) to strong shocks, as it is a sensitive, complex unit.
2. Cut off the shorted part of the flexible cable using nippers, etc. after replacing the optical pickup. For specific details, refer to the replacement procedure in the text. Remove the anti-static pin when replacing the traverse unit. Be careful not to take too long a time when attaching it to the connector.
3. Handle the flexible cable carefully as it may break when subjected to strong force.
4. It is not possible to adjust the semi-fixed resistor that adjusts the laser power. Do not turn it

1.3. Cautions on removing the CD traverse unit

* For removing the CD traverse unit in detail, refer to the "Adjustment Method" section of this manual.

1. Before disconnecting the flexible wire from the connector CN601 on the CD SERVO board, solder the part shown in the figure below.
(Note: If the flexible wire is disconnected from the CN601 without presoldering, it may cause breakdown of the CD pickup assembly.)
2. When reassembling the CD traverse unit, be sure to remove the solder from the soldered part after reconnecting the flexible wire to the CN601.

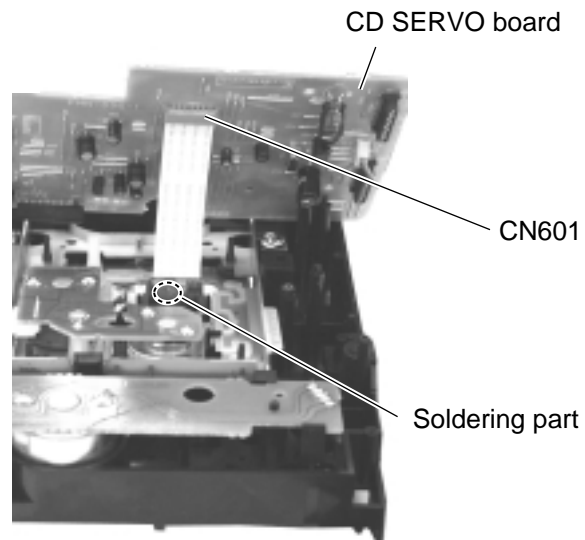
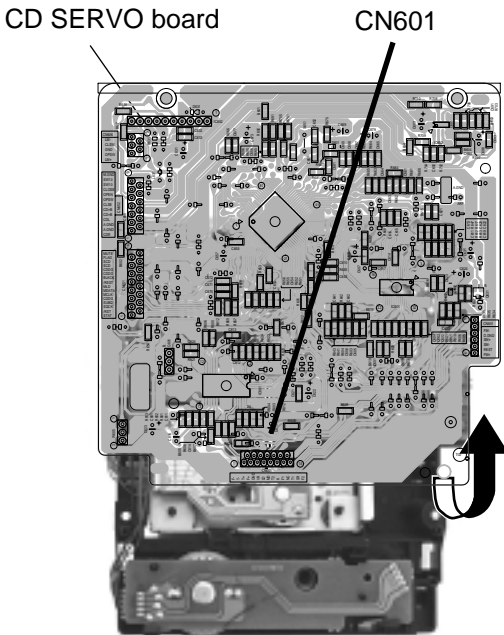

Important for laser products

1.CLASS 1 LASER PRODUCT

2.DANGER : Invisible laser radiation when open and interlock failed or defeated. Avoid direct exposure to beam.

3.CAUTION : There are no serviceable parts inside the Laser Unit. Do not disassemble the Laser Unit. Replace the complete Laser Unit if it malfunctions.

4.CAUTION : The compact disc player uses invisible laserradiation and is equipped with safety switches which prevent emission of radiation when the drawer is open and the safety interlocks have failed or are defeated. It is dangerous to defeat the safety switches.

5.CAUTION : If safety switches malfunction, the laser is able to function.

6.CAUTION : Use of controls, adjustments or performance of procedures other than those specified herein may result in hazardous radiation exposure.

⚠ CAUTION Please use enough caution not to see the beam directly or touch it in case of an adjustment or operation check.

WARNING : Osynlig laserstråling är denna del är öppnad och spårren är urkopplad. Betrakta ej strålen.

VARO : Avattaessa ja suojalukitus ohitettaessa olet alltiina näkymättömälle lasersäteilylle. Älä katso säteeseen.

ADVARSEL : Usynlig laserstråling ved åbning , når sikkerhedsafbrydere er ude af funktion. Undgå udsættelse for stråling.

ADVARSEL : Usynlig laserstråling ved åpning,når sikkerhetsbryteren er avslott. unngå utsettelse for stråling.

REPRODUCTION AND POSITION OF LABELS



WARNING LABEL

**CLASS 1
LASER PRODUCT**

Disassembly method

<Main body>

■ Removing the metal cover

(See Fig.1 and 2)

1. Remove the six screws **A** on the back of the body.
2. Remove the two screws **B** on the side of the body.
3. Pull both sides of the metal cover outward and lift the rear part of the cover.

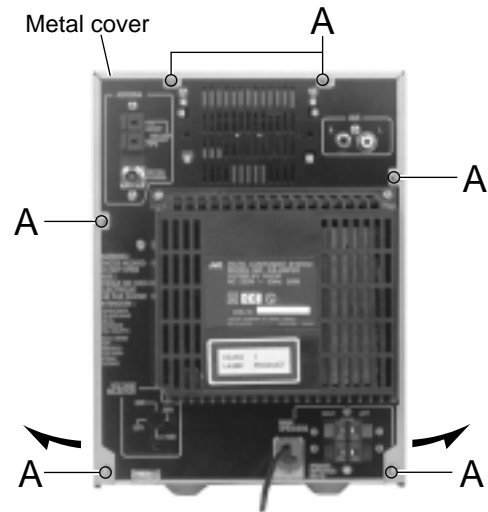

Fig.1

■ Removing the rear cover (See Fig.3)

- Prior to performing the following procedure, remove the metal cover.
1. Remove the two screws **C** on the back of the body.

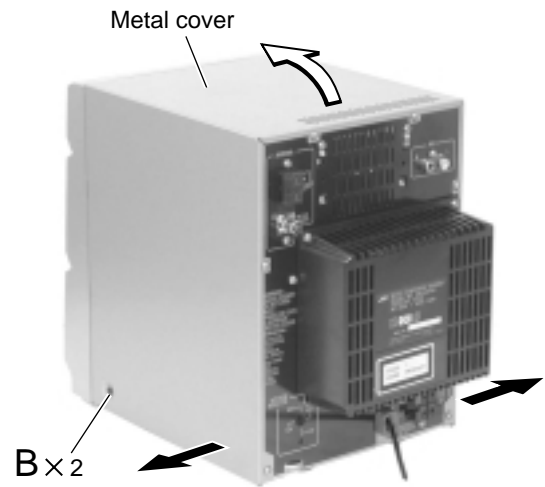

Fig.2

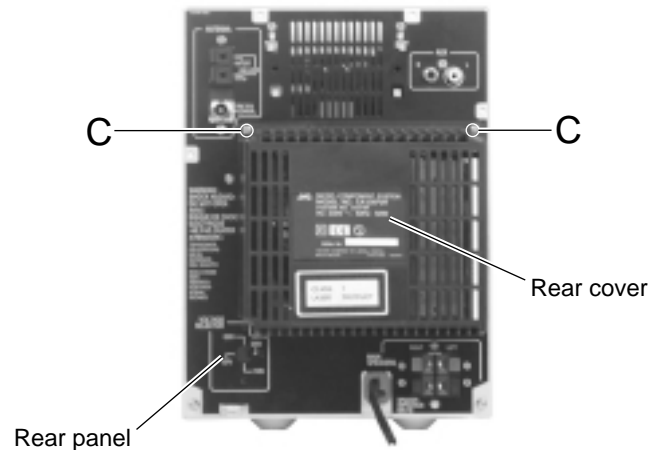

Fig.3

■ Removing the tuner board
(See Fig.4 and 5)

• Prior to performing the following procedure, remove the metal cover.

1. Disconnect the card wire from connector CN1 on the tuner board.
2. Remove the screw **D** on the right side of the body.
3. Remove the two screws **E** on the rear panel.

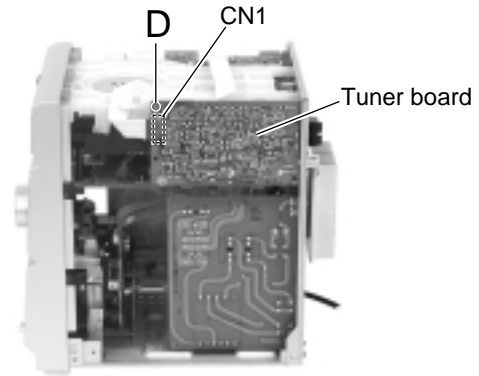

Fig.4

■ Removing the CD mechanism assembly
(See Fig.6 to 8)

• Prior to performing the following procedure, remove the metal cover and the rear cover.

1. Disconnect the card wires from connector CN903, CN904 on the main board on the upper side of the body.
2. Remove the screw **D** attaching the tuner board and the CD mechanism on the right side of the body.
3. Remove the two screws **F** attaching the rear panel and the CD mechanism on the back of the body.
4. Move the rear part of the CD mechanism assembly upwards to disengage the two joints **a** and release from the rear panel.

Pull the front panel toward the front and move the rear part of the CD mechanism assembly upwards. Then pull out the CD mechanism assembly from the front panel backward.

REFERENCE: To remove the CD mechanism assembly efficiently, disconnect the card wire connecting the tuner board with the main board in advance.

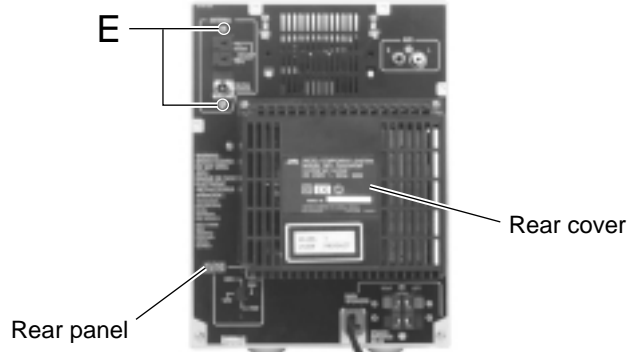

Fig.5

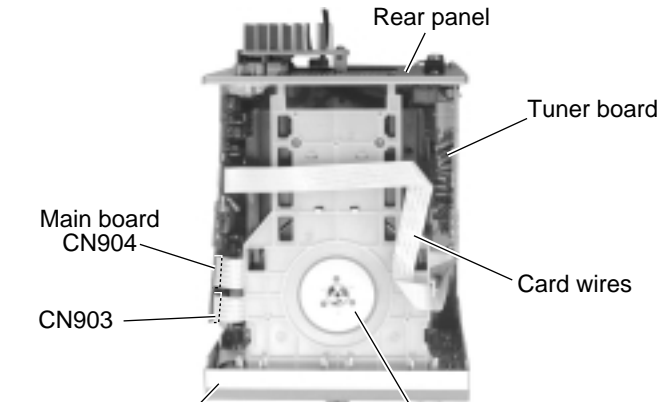

Fig.6

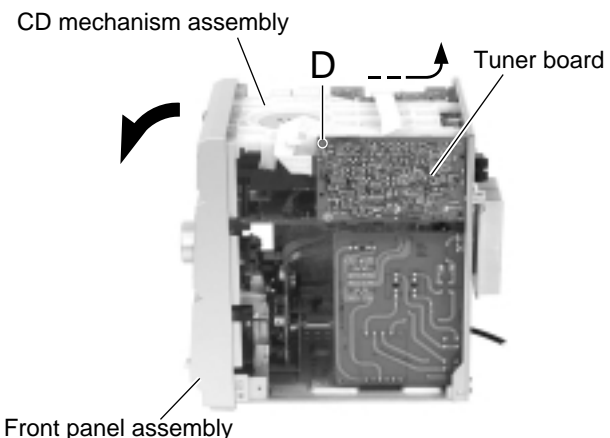

Fig.7

Remove the rear panel (See Fig.8 to 11)

· Prior to performing the following procedure, remove the metal cover, rear cover and the CD mechanism assembly.

1. Remove the five screws **G** attaching the rear panel.
2. Disconnect the card wire from CN902 on the main board.
3. Disengage the lower two joints **b** on each side of the rear panel using a screwdriver and remove the rear panel backward (The tuner board and the fan will be also detached. Remove them as needed).

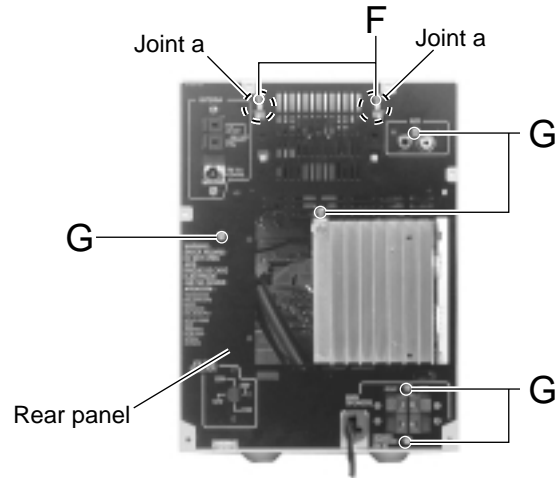

Fig.8

Removing the fan (See Fig.9 and 12)

· Prior to performing the following procedure, remove the metal cover, the rear cover and the CD mechanism assembly.

1. Disconnect the wire from connector CN908 on the main board.
2. Remove the two screws **H** on the back of the body.
3. Move the fan upwards to disengage the four joints **c** and release from the rear panel.

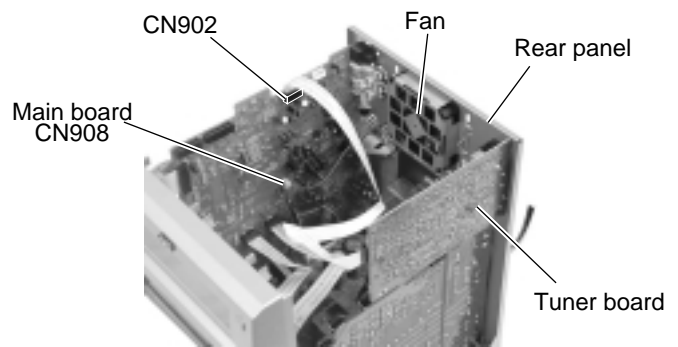

Fig.9

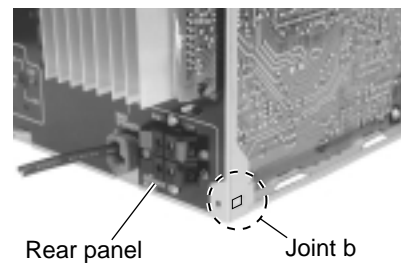

Fig.10

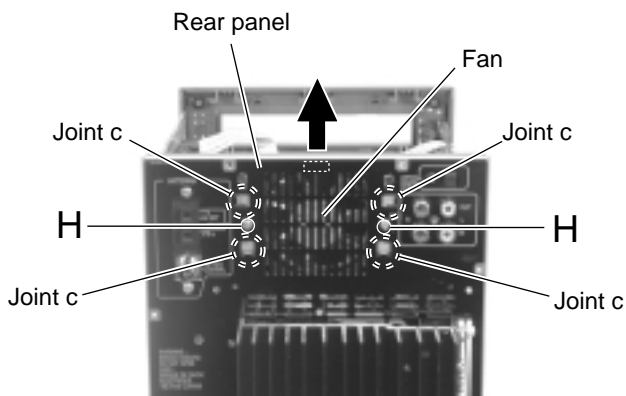

Fig.12

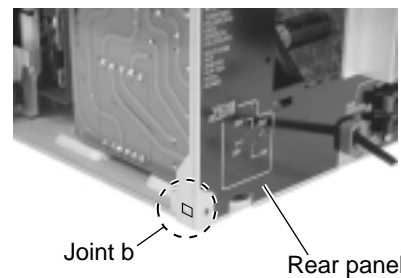

Fig.11

■ Removing the main board / heat sink
(See Fig.13 to 15)

• Prior to performing the following procedure, remove the metal cover, the rear cover, the CD mechanism assembly and the rear panel.

1. Disconnect the card wire from connector CN900, CN901 and CN931 on the main board.

Disconnect the wire from CN906 and FW903 respectively.

2. Disconnect the wire from W950 on the underside of the main board.

3. Remove the two screws **I** attaching the main board to the chassis on the left side of the body and disengage the two joints **c**.

4. Remove the two screws **J** attaching the heat sink to the main board.

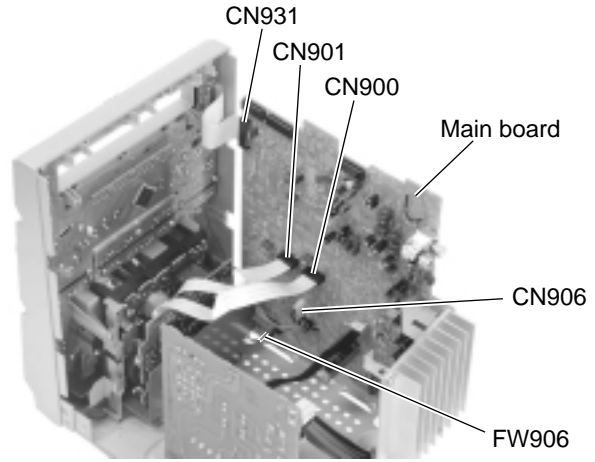

Fig.13

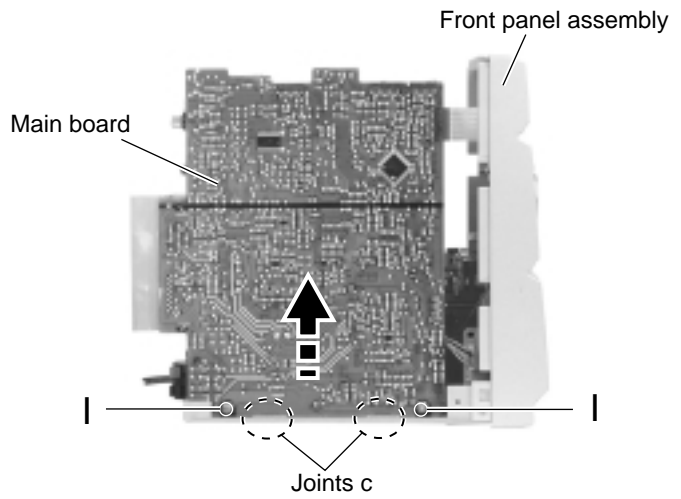

Fig.14

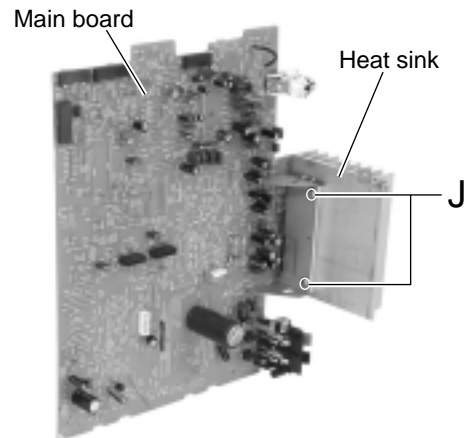

Fig.15

■ Removing the power transformer assembly (See Fig.16 and 17)

• Prior to performing the following procedure, remove the metal cover, the rear cover, the CD mechanism assembly and the rear panel.

1. Remove the cord stopper upwards on the back of the body.
2. Disconnect the power cord from connector J1000 on the board of the power transformer assembly.
3. Disconnect the wire from connector FW903 on the main board.
4. Remove the four screws **K** attaching the power transformer assembly.

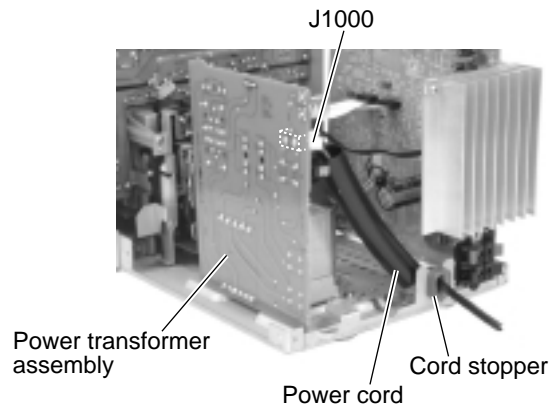

Fig.16

■ Removing the front panel assembly (See Fig.13, 18 and 19)

• Prior to performing the following procedure, remove the metal cover, the rear cover, the CD mechanism assembly and the rear panel.

1. Disconnect the card wire from connector CN900, CN901 and CN931 on the main board (Refer to Fig.13).
2. Disconnect the wire from CN906 and FW903 respectively (Refer to Fig.13).

Disconnect the wire from W950 on the underside of the main board.

3. Remove the two screws **L** on each lower side of the body.
4. Release the lower joints **d** on each side of the body using a screwdriver. Pull out the front panel assembly toward the front.

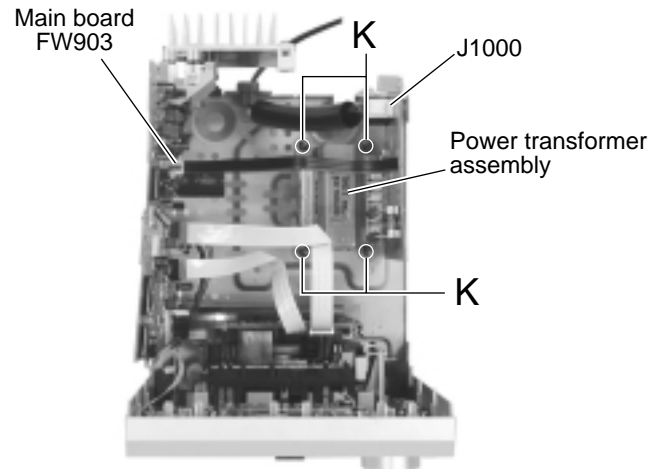

Fig.17

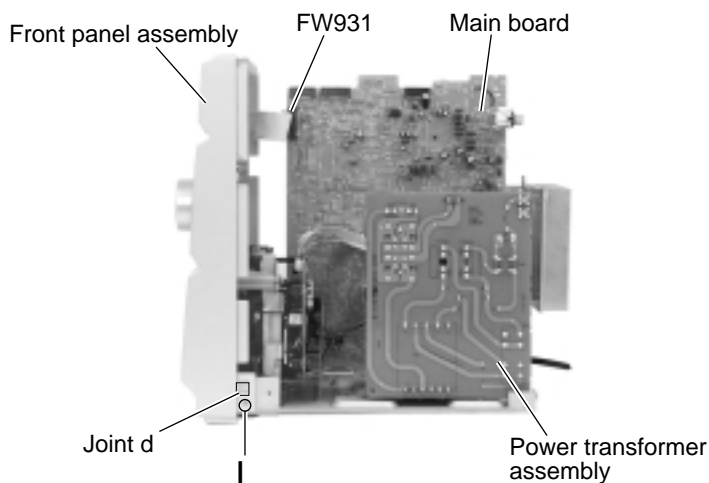

Fig.19

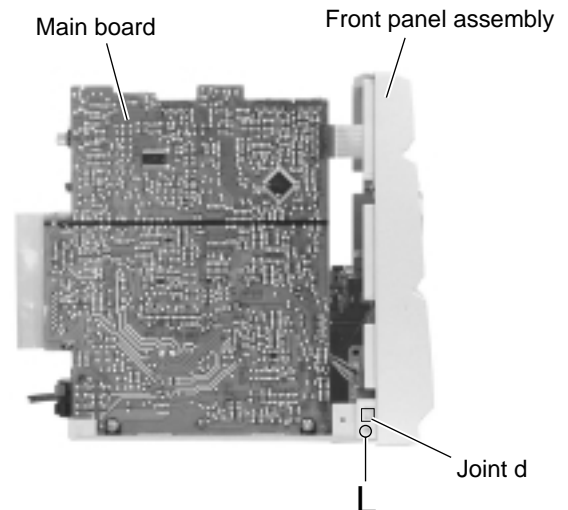

Fig.18

■Removing the display board / switch board (See Fig.20 to 22)

• Prior to performing the following procedure, remove the front panel assembly.

1. Pull out the VOLUME knob on the front panel.
2. Remove the fifteen screws **M** attaching the display board and the switch board on the back of the front panel. Remove the display board with the switch board.
3. Remove the screw **N** attaching the switch board to the LCD holder.
4. If necessary, unsolder the wire extending from connector FW931 on the display board and FW931 on the switch board.
5. If necessary, remove the band bundling the wires extending from the headphone board and the display board.

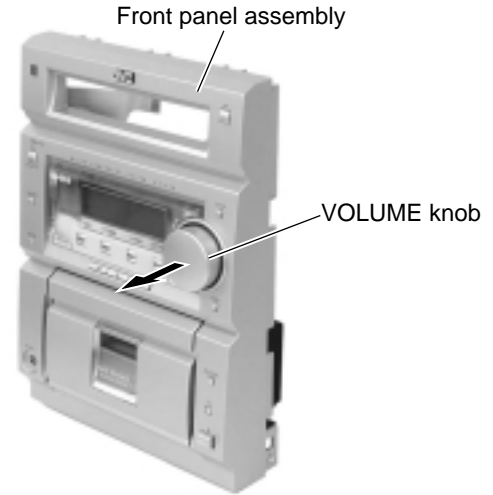

Fig.20

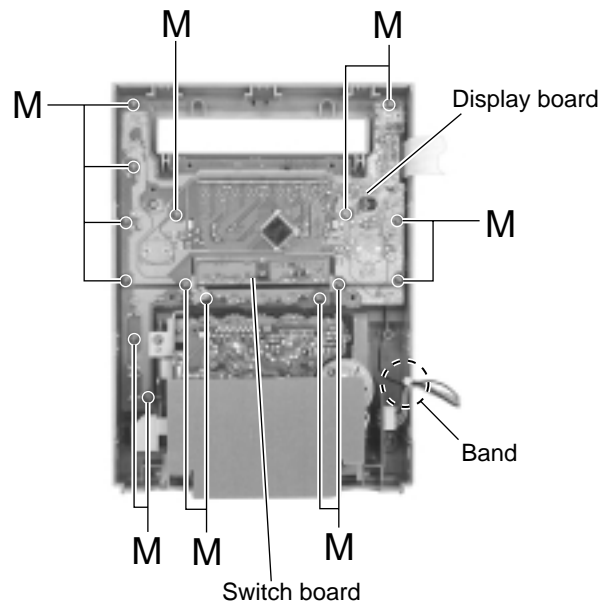

Fig.21

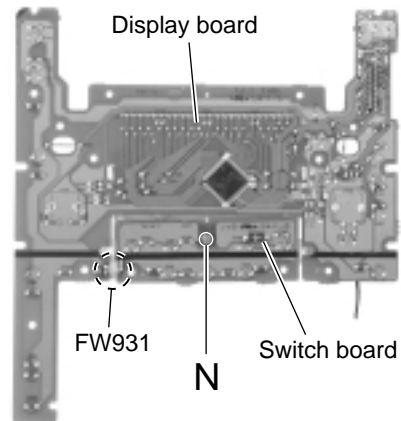

Fig.22

**■Removing the headphone board
(See Fig.23)**

- Prior to performing the following procedure, remove the front panel assembly.
1. Remove the screw **O** on the back of the front panel.
 2. If necessary, remove the band bundling the wire extending from the headphone board and the display board.

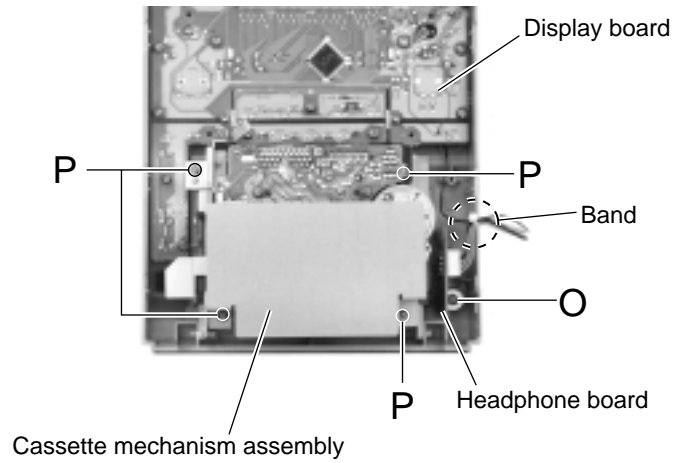

Fig.23

■Removing the cassette mechanism assembly (See Fig.23 and 24)

- Prior to performing the following procedure, remove the front panel assembly.
1. Press the EJCT button on the front panel to open the cassette door.
 2. Remove the four screws **P** on the back of the front panel.

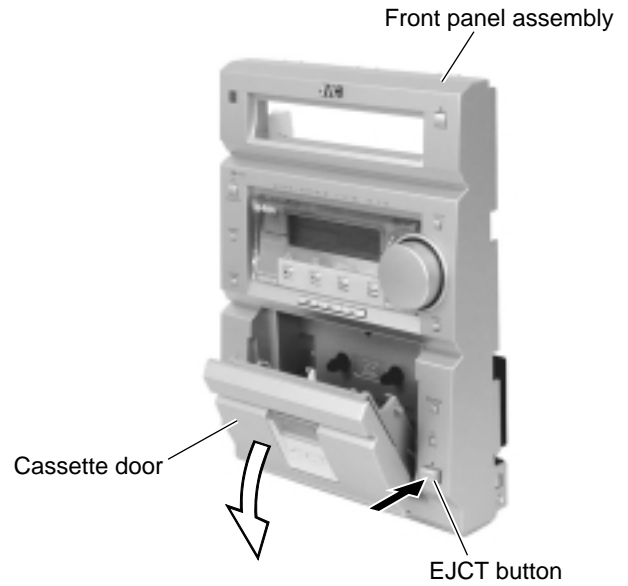

Fig.24

Main adjustment

■ Measurement Instruments Required for Adjustment

1. Low frequency oscillator
This oscillator should have a capacity to output 0dBs to 600 Ω at an oscillation frequency of 50Hz-20kHz.
2. Attenuator impedance : 600 Ω
3. Electronic voltmeter
4. Distortion meter
5. Frequency counter
6. Wow & flutter meter
7. Test tape
VTT703L : Head azimuth
VT712 : Tape speed and running unevenness (3kHz)
VT724 : Reference level (1kHz)
8. Blank tape
TYPE I : AC-225
TYPE II : AC-514
9. Torque gauge : For play and back tension
FWD(TW2111A), REV(TW2121a) and
FF/REW(TW2231A)
10. Test disc: CTS-1000

■ Measurement conditions

- Power supply voltage
: AC230V (50Hz)---B/E/EE/EN
: AC110/127V/230V(50/60Hz)
: UB/UF/US/UX/U
- Reference output : Speaker : 0.775V/4 Ω
: Headphone : 0.077V/32 Ω
- Reference frequency and
input level ----- 1kHz, AUX : -8dBs
MIX MIC: -54dBs (UB/UF/US/UX/U)
Input for confirming recording and playback
characteristics ----- AUX : -28dBs
Measurement output terminal ----- at Speaker J3002
※ Load resistance ----- 4 Ω

● Radio Input signal

- AM frequency ----- 400Hz
AM modulation ----- 30%
FM frequency ----- 400Hz
FM frequency deviation ----- 22.5kHz

● Tuner section

- B/E/EN version
FM Band cover: 87.5~108MHz
MW Band cover: 522~1,629kHz
LW Band cover: 144~288kHz
- EE version
FM Band cover: 65~74MHz, 87.5~108MHz
MW Band cover: 522~1,629kHz
LW Band cover: 144~288kHz
- UB/UF/US/UX/U version
FM Band cover: 87.5~108MHz
MW Band cover: 531~1,602kHz, 530~1,710kHz
SW Band cover: SW1 2.3~6.995MHz
: SW2 7~21.85MHz
- Voltage applied to tuner ----- +B : DC5.7V
VT : DC 12V
- Reference measurement
output ----- 26.1mV(0.28V)/3 Ω
Input positions ----- AM : Standard loop antenna
FM : TP1 (hot) and TP2 (GND)

● Standard measurement position of volume

- Function switch ----- to Tape
Beat cut switch ----- to Cut
Super Bass/Active hyper Bass ----- to OFF
Bass Treble ----- to Center
Adjustment of main volume to reference output
VOL : 28

Precautions for measurement

1. Apply 30pF and 33k Ω to the IF sweeper output side and 0.082 μ F and 100k Ω in series to the sweeper input side.
2. The IF sweeper output level should be made as low as possible within the adjustable range.
3. Since the IF sweeper is a fixed device, there is no need to adjust this sweeper.
4. Since a ceramic oscillator is used, there is no need to perform any MIX adjustment.
5. Since a fixed coil is used, there is no need to adjust the FM tracking.
6. The input and output earth systems are separated. In case of simultaneously measuring the voltage in both of the input and output systems with an electronic voltmeter for two channels, therefore, the earth should be connected particularly carefully.
7. In the case of BTL connection amp., the minus terminal of speaker is not for earthing. Therefore, be sure not to connect any other earth terminal to this terminal. This system is of an BTL system.
8. For connecting a dummy resistor when measuring the output, use the wire with a greater code size.
9. Whenever any mixed tape is used, use the band pass filter (DV-12).

<<Arrangement of Adjusting Position>>

Cassette mechanism section

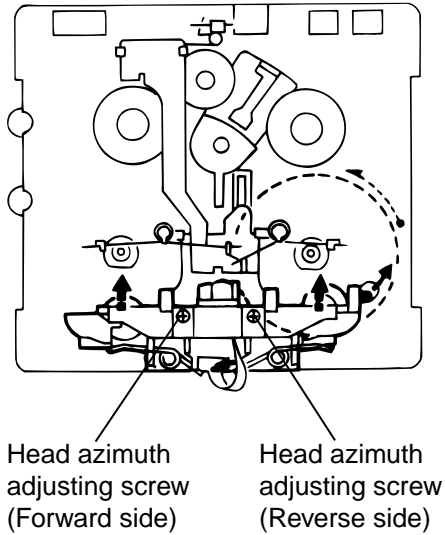

Cassette mechanism section (Back side)

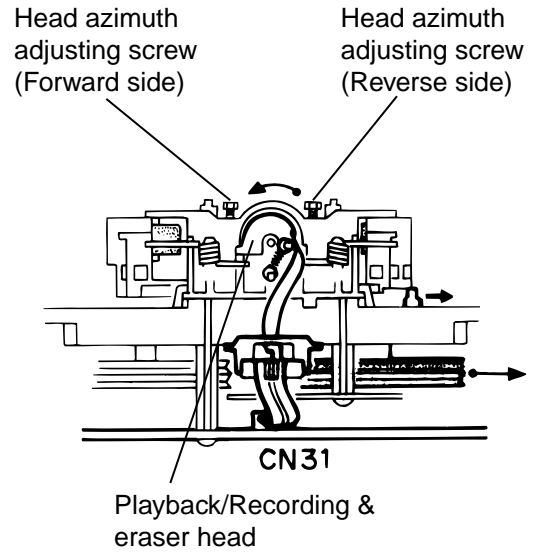

Cassette AMP board

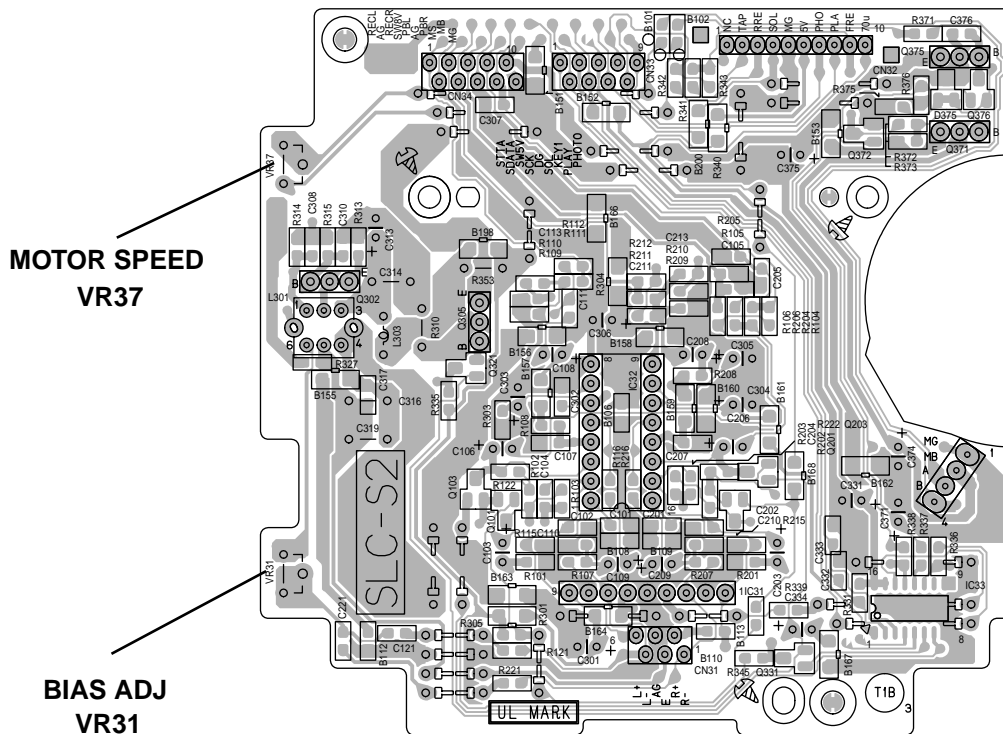

■ Tape Recorder Section

Items	Measurement conditions	Measurement method	Standard Values	Adjusting positions
Confirmation of head angle	Test tape : VTT703L (8kHz) Measurement output terminal : Speaker terminal Speaker R (Load resistance: 4Ω) : Headphone terminal	1 Playback the test tape VTT703L (8kHz) 2 With the recording & playback mechanism, adjust the head azimuth screw so that the forward and reverse output levels become maximum. After adjustment, lock the head azimuth at least by half turn. 3 In either case, this adjustment should be performed in both the forward and reverse directions with the head azimuth screw.	Maximum output	Adjust the head azimuth screw only when the head has been changed.
Confirmation of tape speed	Test tape : VT712 (3kHz) Measurement output terminal : Headphone terminal	Adjust VR37 so that the frequency counter reading becomes 2,940~3,090Hz \pm when playing back the test tape VT712 (3kHz) with playback and recording mechanism after ending forward winding of the tape.	Tape speed of deck : 2,940 ~ 3,090Hz	VR37

■ Reference Values for Confirmation Items

Items	Measurement conditions	Measurement method	Standard Values	Adjusting positions
Difference between the forward and reverse speed	Test tape : VT712 (3kHz) Measurement output terminal : Speaker terminal Speaker R (Load resistance: 4 Ω) Measurement output terminal : Headphone	When the test tape VT712 (3kHz) has been played back with the recording and playback mechanism at the beginning of forward winding, the frequency counter reading of the difference between both of the mechanism should be 6.0Hz or less.	6.0Hz or less	Head azimuth screw
Wow & flutter	Test tape : VT712 (3kHz) Measurement output terminal : Headphone terminal	When the test tape VT712 (3kHz) has been played back with the recording and playback mechanism at the beginning of forward winding, the frequency counter reading of wow & flutter should be 0.25% or less (WRMS).	0.25% or less (WRMS)	

■ Electrical Performance

Items	Measurement conditions	Measurement method	Standard Values	Adjusting positions
Adjustment of recording bias current (Reference Value)	<ul style="list-style-type: none"> ▪ Mode: Forward or reverse mode ▪ Recording mode ▪ Test tape : AC-514 to TYPE II and AC-225 to TYPE I Measurement output terminal : Both recording and headphone terminals	<ol style="list-style-type: none"> 1 With the recording and playback mechanism, load the test tapes (AC-514 to TYPE II and AC-225 to TYPE I), and set the mechanism to the recording and pausing condition in advance. 2 After connecting 100 Ω in series to the recorder head, measure the bias current with a valve voltmeter at both of the terminals. 3 After resetting the [PAUSE] mode, start recording. At this time, adjust VR31 for Lch and VR32 for Rch so that the recording bias current values become 4.0 μ A (TYPE I) and 4.20 μ A (TYPE II). 	AC-225 : 4.20 μ A AC-514 : 4.0 μ A	VR31
Adjustment of recording and playback frequency characteristics	Reference frequency : 1kHz and 10kHz (REF.: -20dB) Test tape : AC-514 to TYPE II Measurement input terminal : OSC IN	<ol style="list-style-type: none"> 1 With the recording and playback mechanism, load the test tapes (AC-514 to TYPE II), and set the mechanism to the recording and pausing condition in advance. 2 While repetitively inputting the reference frequency signal of 1kHz and 10kHz from OSC IN, record and playback the tape. 3 While recording and playback the test tape in TYPE II, adjust VR31 for Lch and VR32 for Rch so that the output deviation between 1kHz and 10kHz becomes -1dB \pm 2dB. 	Output deviation between 1kHz and 10kHz : -1dB \pm 2dB	VR31

■ Reference Values for Electrical Function Confirmation Items

Items	Measurement conditions	Measurement method	Standard Values	Adjusting positions
Recording bias frequency	Forward or reverse <ul style="list-style-type: none"> ▪ Test tape : TYPE II (AC-514) ▪ Measurement terminal : BIAS TP on P.C. board 	<ol style="list-style-type: none"> 1 While changing over to and from BIAS 1 and 2, confirm that the frequency is changed. 2 With the recording and playback mechanism, load the test tape (AC-514 to TYPE II), and set the mechanism to the recording and pausing condition in advance. 3 Confirm that the BIAS TP frequency on the P.C. board is 100kHz \pm 6kHz. 	100 kHz \pm 6 kHz	
Eraser current (Reference value)	Forward or reverse <ul style="list-style-type: none"> ▪ Recording mode ▪ Test tape : AC-514 to TYPE II and AC-225 to TYPE I Measurement terminal : Both of the eraser head terminals	<ol style="list-style-type: none"> 1 While recording and playback mechanism, load the test tapes (AC-514 to TYPE II and AC-225 to TYPE I), and set the mechanism to the recording and pausing conditions in advance. 2 After setting to the recording conditions, connect 1W in series to the eraser head on the recording and playback mechanism side, and measure the eraser current from both of the eraser terminals. 	TYPE II : 120 mA TYPE I : 75 mA	

Flow of functional operation until TOC read (CD)

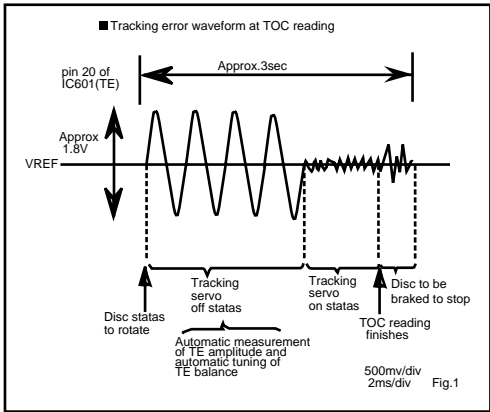
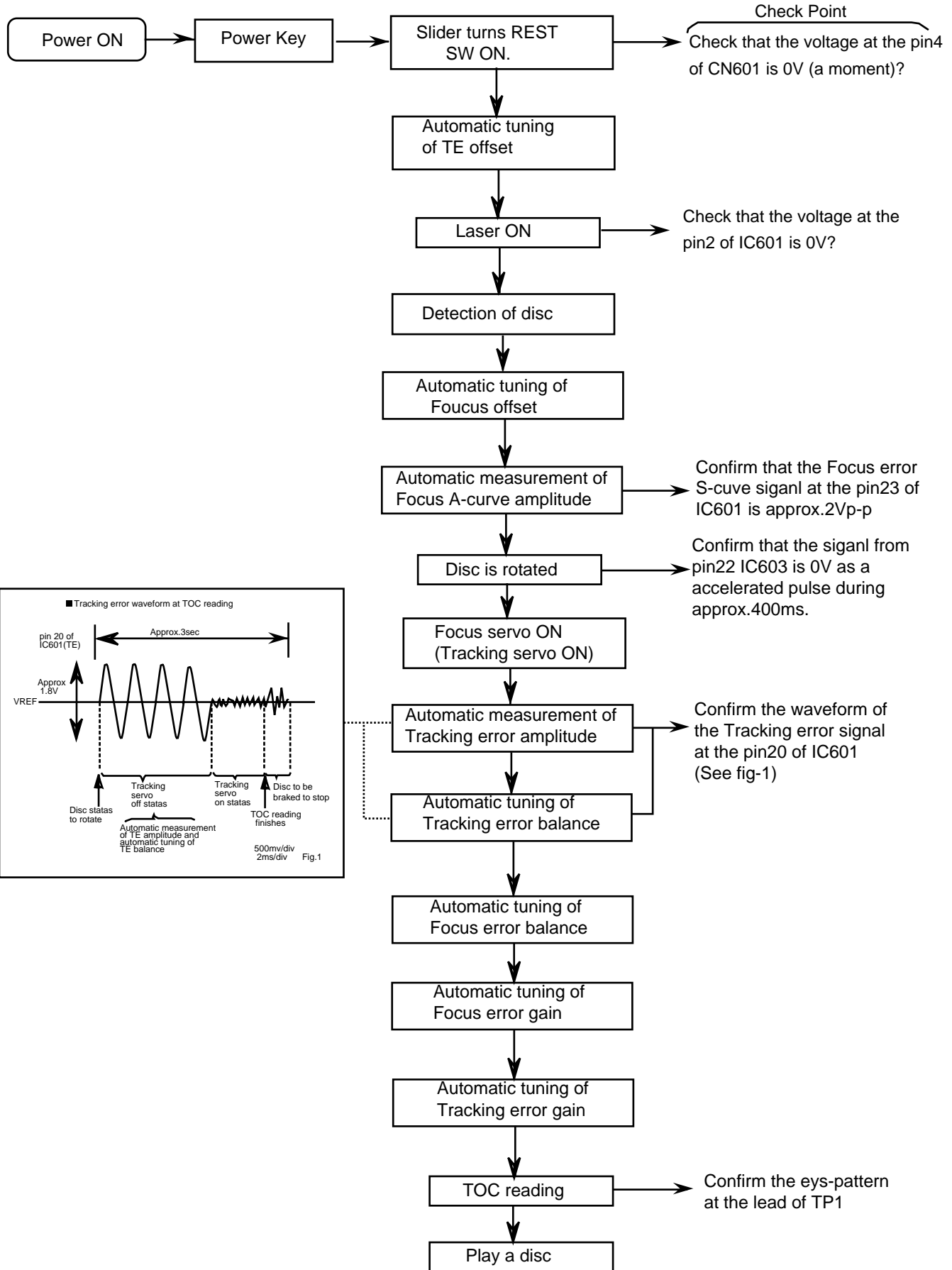

Maintenance of laser pickup

- (1) Cleaning the pick up lens
 Before you replace the pick up, please try to clean the lens with a alcohol soaked cotton swab.
- (2) Life of the laser diode (Fig.1)
 When the life of the laser diode has expired, the following symptoms will appear.
 - (1) The level of RF output (EFM output: amplitude of eye pattern) will below.

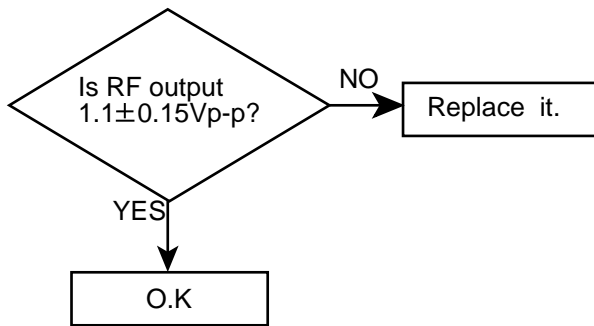

(Fig.1)

- (3) Semi-fixed resistor on the APC PC board
 The semi-fixed resistor on the APC printed circuit board which is attached to the pickup is used to adjust the laser power. Since this adjustment should be performed to match the characteristics of the whole optical block, do not touch the semi-fixed resistor.
 If the laser power is lower than the specified value, the laser diode is almost worn out, and the laser pickup should be replaced.
 If the semi-fixed resistor is adjusted while the pickup is functioning normally, the laser pickup may be damaged due to excessive current.

Replacement of laser pickup

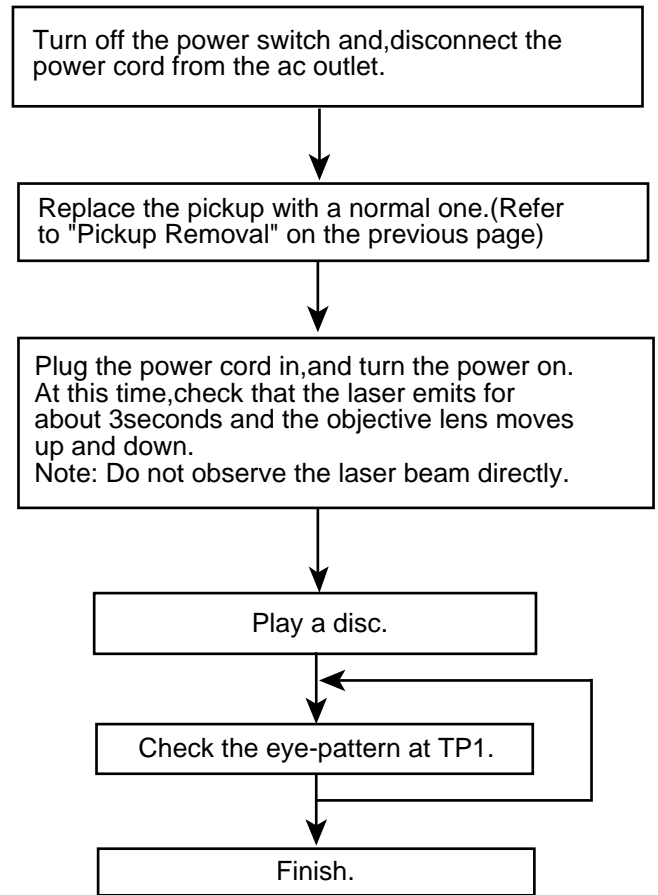

Description of major ICs

■ UPD780058 (IC931) : Main micon

1. Pin layout

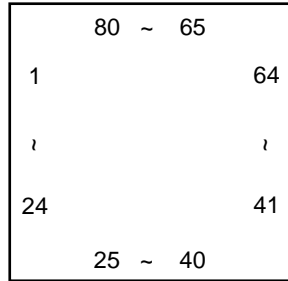

2. Pin function

Pin No.	Port	Name	I/O	Function	Function
1	P15/AN15	SAFETY0	I	Irregular voltage detection 0	Safety
2	P16/AN16	DOOR_RST	I	REST/CLOSE switch detect port	Door
3	P17/AN17	CDSAFETY	I	CD safety voltage detect port	Safety
4	AVss				
5	P130/ANO0	EQSW	O	CD speed control	CD
6	P131/ANO1	GCTRL	O	CD Gain Control	CD
7	AVREF1				
8	P70/SI2/RxD0	QRIN	I	Q-code data input port	CD
9	P71/SO2/TxD0				
10	P72/ $\overline{\text{SCK2}}$ /ASCK	SQCK	O	Q-code serial clock	CD
11	P20/SI1	STAT	I	CD status input port	CD
12	P21/SO1	MDATA	O	CD data input port	CD
13	P22/ $\overline{\text{SCK1}}$	MCLK	O	CD data clock	CD
14	P23/STB/TxD1	_XRST	O	CD reset	CD
15	P24/BUSY/RxD1	MLD	O	CD command ready signal	CD
16	P25/SI0/SB0	MUTE	O	BTL mute control port	CD
17	P26/SO0/SB1	SDATA	O	Serial Date (Tuner PLL/Tape IC)	Tuner/Tape
18	P27/ $\overline{\text{SCK0}}$	SCK	O	Serial Clock (Tuner PLL/Tape IC)	Tuner/Tape
19	P40/AD0				
20	P41/AD1	CLOSE	I	Door close switch input port	Door
21	P42/AD2	OPEN	I	Door poen switch input port	Door
22	P43/AD3	F_CD	O	CD Function ("H"=CD)	CD
23	P44/AD4				
24	P45/AD5	_AHB1	O	Subwoofer Amp AHB control	Sound (P7only)
25	P46/AD6	VOLCE	O	Volumn Chip Enable	Sound
26	P47/AD7				
27	P50/A8	_F_AUX			AUX
28	P51/A9	_PBMUTE	O	Tape play mute ("L"=mute)	Tape
29	P52/A10	_SMUTE	O	System mute	Sound
30	P53/A11	SPKMUTE	O	Speaker mute	Sound
31	P54/A12	_AHB	O	Active Hyper Bass On/off ("L"=ON)	Sound
32	P55/A13	P_OUT	O	Power On/off ("H"=Power On)	AMP
33	Vss1				
34	P56/A14	PROTR	O	Protector	Safety
35	P57/A15	MODEL1	I	MODEL 0: P3/P5; 1: P7	
36	P60	MODEL2	I	MODEL2 0: P3; 1: P5	
37	P61				
38	P62				

Pin No.	Port	Name	I/O	Function	Function
39	P63				
40	P64/RD	LEDRV	O	Lite LED indicate Reverse	LED
41	P65/WR	LED_REC	O	Lite LED indicate REC	LED
42	P66/WAIT	LEDFR	O	Lite LED indicate Forward	LED
43	P67/ASTB	STTA	O	Tape IC Strobe	Tape
44	P30/TO0	LCDAT	O	LCD data	LCD
45	P31/TO1	LMODE	O	LCD date mode control	LCD
46	P32/TO2	LCDCK	O	LCD clock	LCD
47	P33/TI1				
48	P34/TI2	REEL	I	Tape End Detection	Tape
49	P35/PCL	INH_	O	LCD Driver inhibit ("L" at end of tran)	LCD
50	P36/BUZ	LCDCE	O	LCD driver chip enable	LCD
51	P37	DIMCTL	O	LCD DIM Control	LED
52	P120/RTP0	VOLP	I	Volumn Plus	Sound
53	P121/RTP1	LEDCTL	O	Power Standby LED control	LED
54	P122/RTP2	BASM	I	Bass Minus	Sound (P7 only)
55	P123/RTP3	VOLM	I	Volumn Minus	Sound
56	P124/RTP4	BASP	I	Bass plus	Sound (P7 only)
57	P125/RTP5	PERIOD	O	Tuner PLL Strode	Tuner
58	P126/RTP6	F_TU	O	Tuner Function ("H"=TUNER)	Tuner
59	P127/RTP7	BUZ	O	Back up power detect ("H"=BACKUP)	Backup
60	RESET				
61	P00/INTP0/TI00	_REM	I	Remote control input	Remote con
62	P01/INTP1/TI01	RDCK	I	RDS clock	Tuner
63	P02/INTP2	_MPX	I	FM Stereo Detection ("L"=STEREO)	Tuner
64	P03/INTP3				
65	P04/INTP4	BCTL	O	Switched 5V controller ("H"=5Vüf off)	AMP
66	P05/INTP5	BLKCK	I	Block clock input port	CD
67	Vss0				
68	VDD1				
69	X2				
70	X1				
71	IC (VPP)				
72	XT2				
73	XT1/P07				
74	VDD0				
75	AVREF0				
76	P10/ANI0	SAFETY1	I	Irregular voltage detection 1	Safety
77	P11/ANI1	TAPE0	I	Tape Switch 0	Tape
78	P12/ANI2	TAPE1	I	Tape Switch 1	Tape
79	P13/ANI3	KEY1	I	Unit Key input 1	Key
80	P14/ANI4	KEY2	I	Unit Key input 0	Key

■ LA6541 (IC801) : Focus & Spindle & Feed & Tracking BTL driver

1. Pin Layout & block diagram

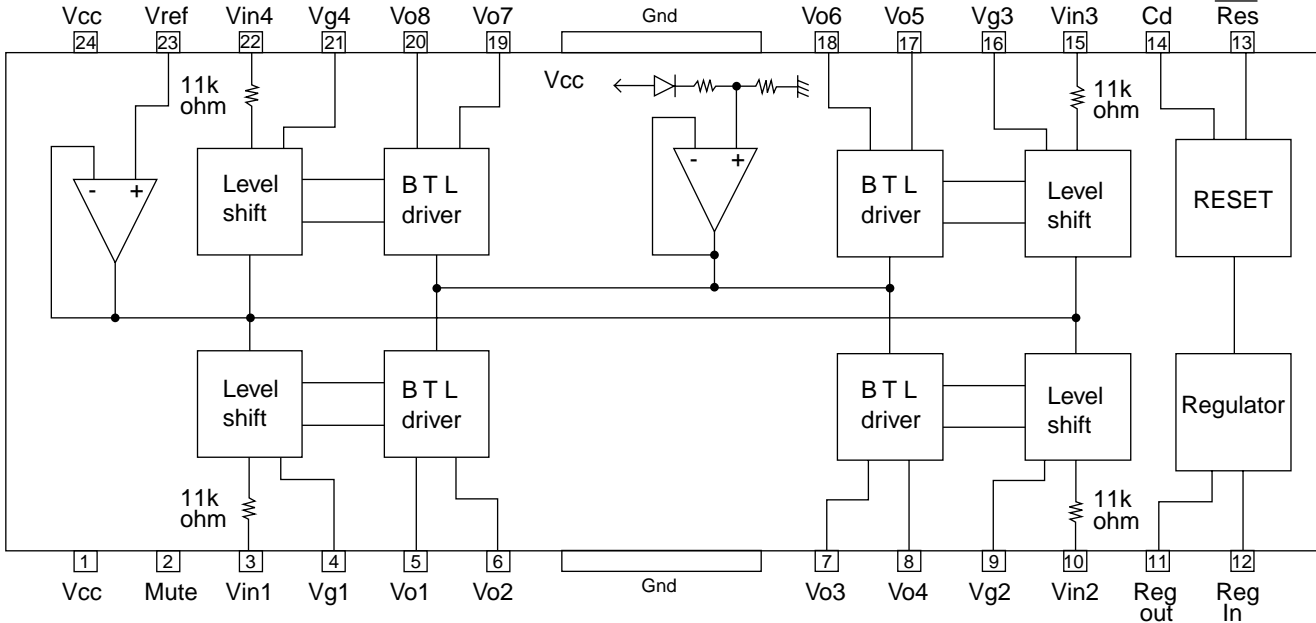

2. Pin function

Pin No.	Symbol	Function
1	Vcc	Power supply (Shorted to pin 24)
2	Mute	All BTL amplifier outputs ON/OFF
3	Vin1	BTL AMP 1 input pin
4	Vg1	BTL AMP 1 input pin (For gain adjustment)
5	Vo1	BTL AMP 1 input pin (Non inverting side)
6	Vo2	BTL AMP 1 input pin (Inverting side)
7	Vo3	BTL AMP 2 input pin (Inverting side)
8	Vo4	BTL AMP 2 input pin (Non inverting side)
9	Vg2	BTL AMP 2 input pin (For gain adjustment)
10	Vin2	BTL AMP 2 input pin
11	Reg Out	External transistor collector (PNP) connection. 5V power supply output
12	Reg In	External transistor (PNP) base connection
13	Res	Reset output
14	Cd	Reset output delay time setting (Capacitor connected externally)
15	Vin3	BTL AMP 3 input pin
16	Vg3	BTL AMP 3 input pin (For gain adjustment)
17	Vo5	BTL AMP 3 output pin (Non inverting side)
18	Vo6	BTL AMP 3 output pin (Inverting side)
19	Vo7	BTL AMP 4 output pin (Inverting side)
20	Vo8	BTL AMP 4 output pin (Non inverting side)
21	Vg4	BTL AMP 4 output pin (For gain adjustment)
22	Vin4	BTL AMP 4 output pin
23	Vref	Level shift circuit's reference voltage application
24	Vcc	Power supply (Shorted to pin 1)

■ MN662748RPM (IC651) : Digital servo & digital signal processor

1. Pin layout

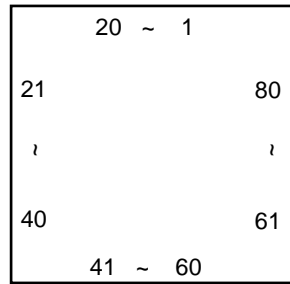

2. Block diagram

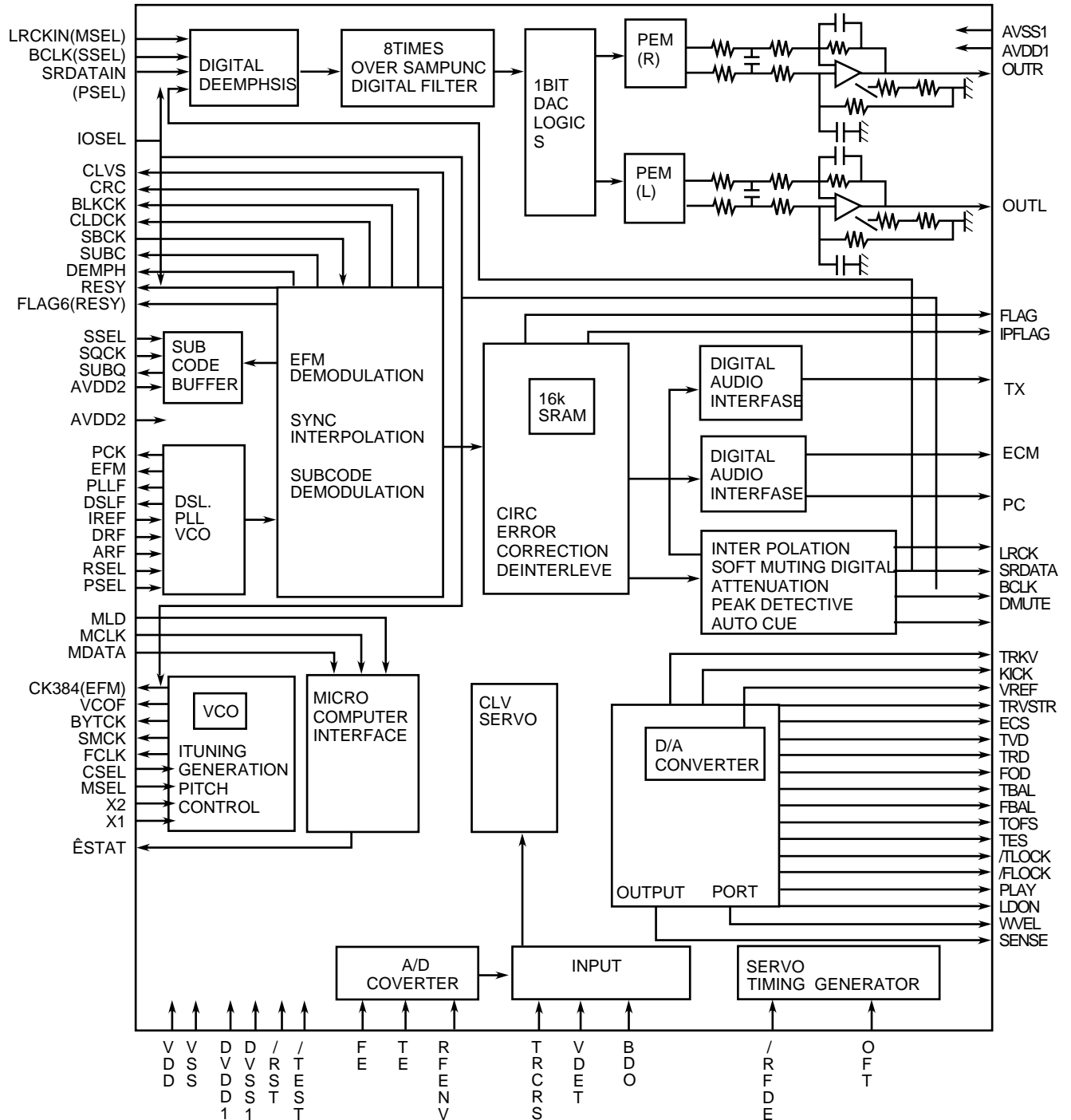

3. Pin function

Pin No.	Symbol	I/O	Function	Pin No.	Symbol	I/O	Function
1	BCLK	O	Not used	41	TES	O	Tracking error shunt signal output (H:shunt)
2	LRCK	O	Not used	42	PLAY	—	Not used
3	SRDATA	O	Not used	43	WVEL	—	Not used
4	DVDD1	—	Power supply (Digital)	44	ARF	I	RF signal input
5	DVSS1	—	Connected to GND	45	IREF	I	Reference current input pin
6	TX	O	Digital audio interface output	46	DRF	I	Bias pin for DSL
7	MCLK	I	CPU command clock signal input (Data is latched at signal's rising point)	47	DSL F	I/O	Loop filter pin for DSL
8	MDATA	I	CPU command data input	48	PLL F	I/O	Loop filter pin for PLL
9	MLD	I	CPU command load signal input	49	VCOF	—	Not used
10	SENSE	O	Sense signal output	50	AVDD2	—	Power supply (Analog)
11	FLOCK	O	Focus lock signal output Active :Low	51	AVSS2	—	Connected to GND (Analog)
12	TLOCK	O	Tracking lock signal output Active :Low	52	EFM	—	Not used
13	BLKCK	O	sub-code/block/clock signal output	53	PCK	—	Not used
14	SQCK	I	Outside clock for sub-code Q resister input	54	PDO	—	Not used
15	SUBQ	O	Sub-code Q -code output	55	SUBC	—	Not used
16	DMUTE	—	Connected to GND	56	SBCK	—	Not used
17	STATUS	O	Status signal (CRC,CUE,CLVS,TTSTOP,ECLV,SQOK)	57	VSS	—	Connected to GND (for X'tal oscillation circuit)
18	RST	I	Reset signal input (L:Reset)	58	XI	I	Input of 16.9344MHz X'tal oscillation circuit
19	SMCK	—	Not used	59	X2	O	Output of X'tal oscillation circuit
20	PMCK	—	Not used	60	VDD	—	Power supply (for X'tal oscillation circuit)
21	TRV	O	Traverse enforced output	61	BYTCK	—	Not used
22	TVD	O	Traverse drive output	62	CLDCK	—	Not used
23	PC	—	Not used	63	FLAG	—	Not used
24	ECM	O	Spindle motor drive signal (Enforced mode output) 3-State	64	IPPLAG	—	Not used
25	ECS	O	Spindle motor drive signal (Servo error signal output)	65	FLAG	—	Not used
26	KICK	O	Kick pulse output	66	CLVS	—	Not used
27	TRD	O	Tracking drive output	67	CRC	—	Not used
28	FOD	O	Focus drive output	68	DEMPH	—	Not used
29	VREF	I	Reference voltage input pin for D/A output block (TVD,FOD,FBA,TBAL)	69	RESY	—	Not used
30	FBAL	O	Focus Balance adjust signal output	70	IOSEL	—	pull up
31	TBAL	O	Tracking Balance adjust signal output	71	TEST	—	pull up
32	FE	I	Focus error signal input (Analog input)	72	AVDD1	—	Power supply (Digital)
33	TE	I	Tracking error signal input (Analog input)	73	OUT L	O	Lch audio output
34	RF ENV	I	RF envelope signal input (Analog input)	74	AVSS1	—	Connected to GND
35	VDET	I	Vibration detect signal input (H:detect)	75	OUT R	O	Rch audio output
36	OFT	I	Off track signal input (H:off track)	76	RSEL	—	pull up
37	TRCRS	I	Track cross signal input	77	CSEL	—	Connected to GND
38	RFDET	I	RF detect signal input (L:detect)	78	PSEL	—	Connected to GND
39	BDO	I	BDO input pin (L:detect)	79	MSEL	—	Connected to GND
40	LDON	O	Laser ON signal output (H:on)	80	SSEL	—	Pull up

■ BA15218F-XE (IC904) : Dual operation amplifier

1. Pin layout

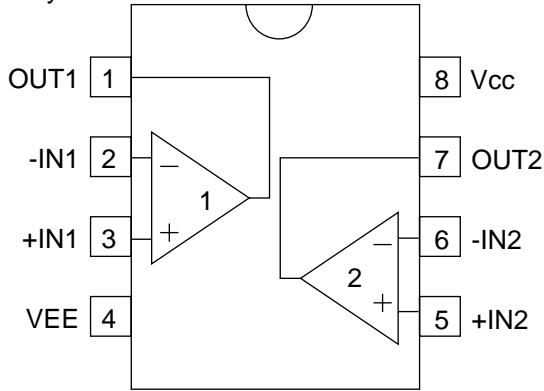

2. Block diagram

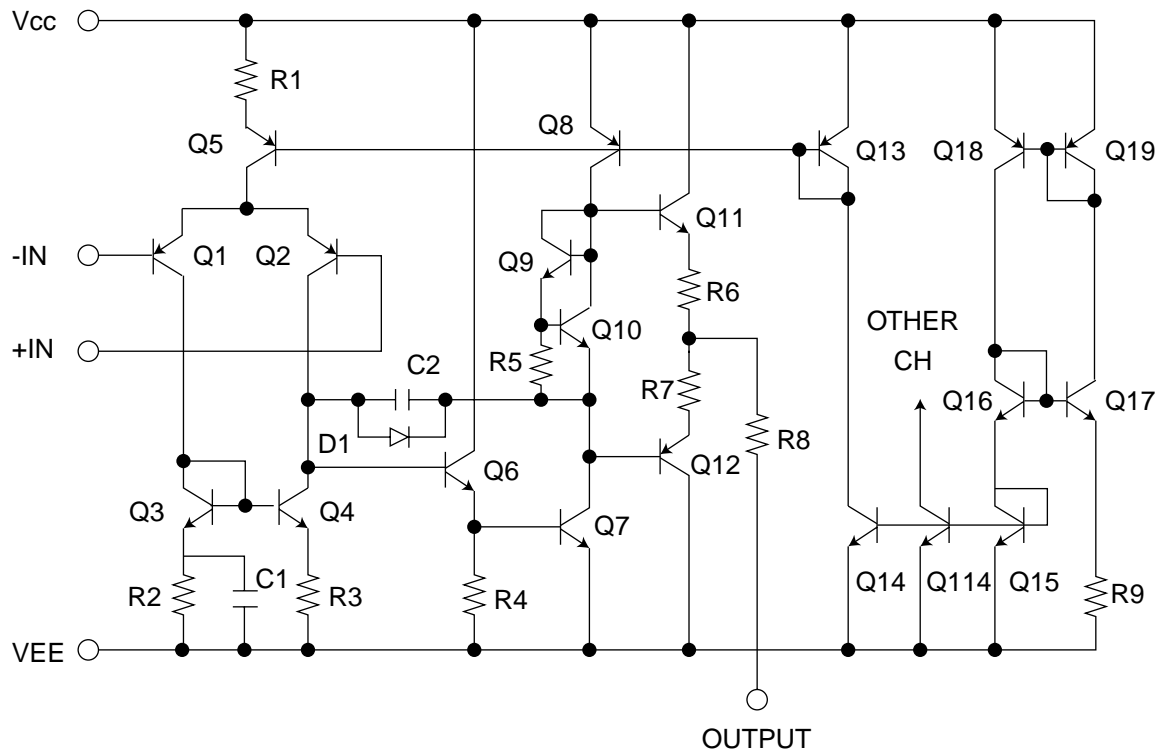

■ KIA78S06P-T (IC933) : Regulator

1. Pin layout

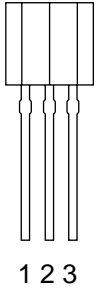

2. Block diagram

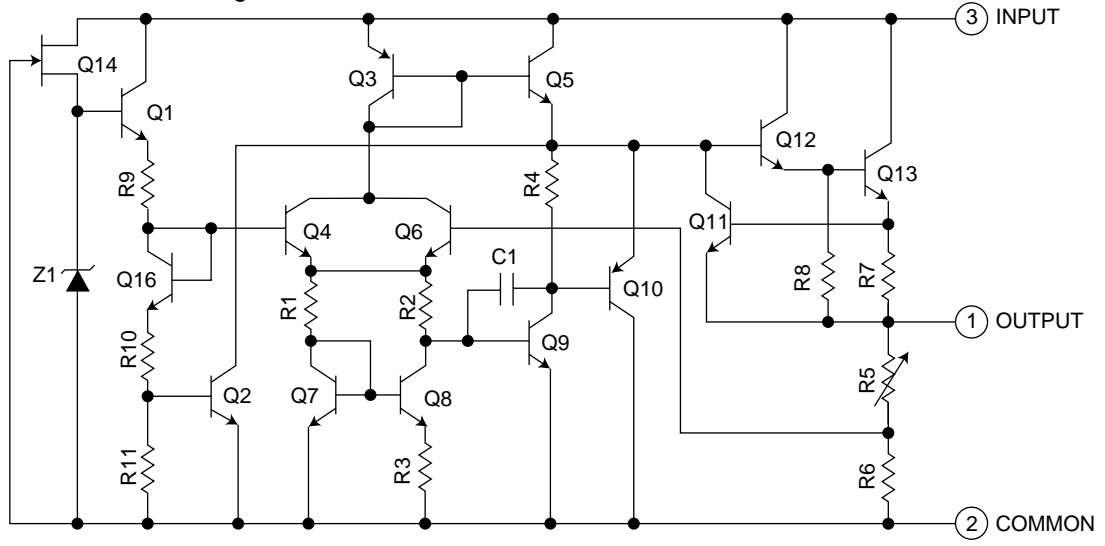

■ LA4628 (IC905) : Power amp

1. Pin layout

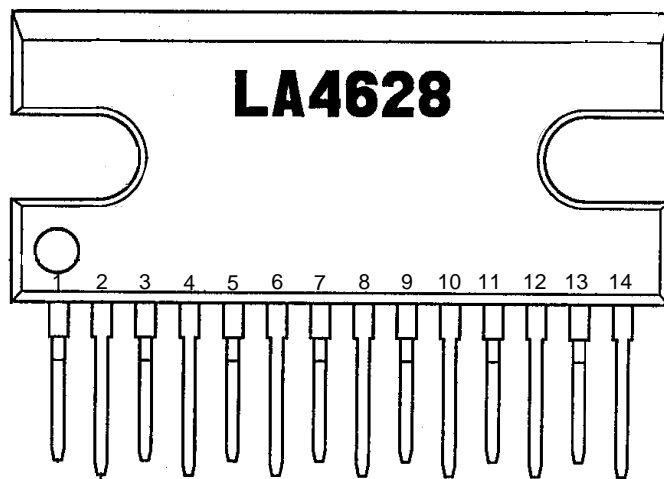

2. Block diagram

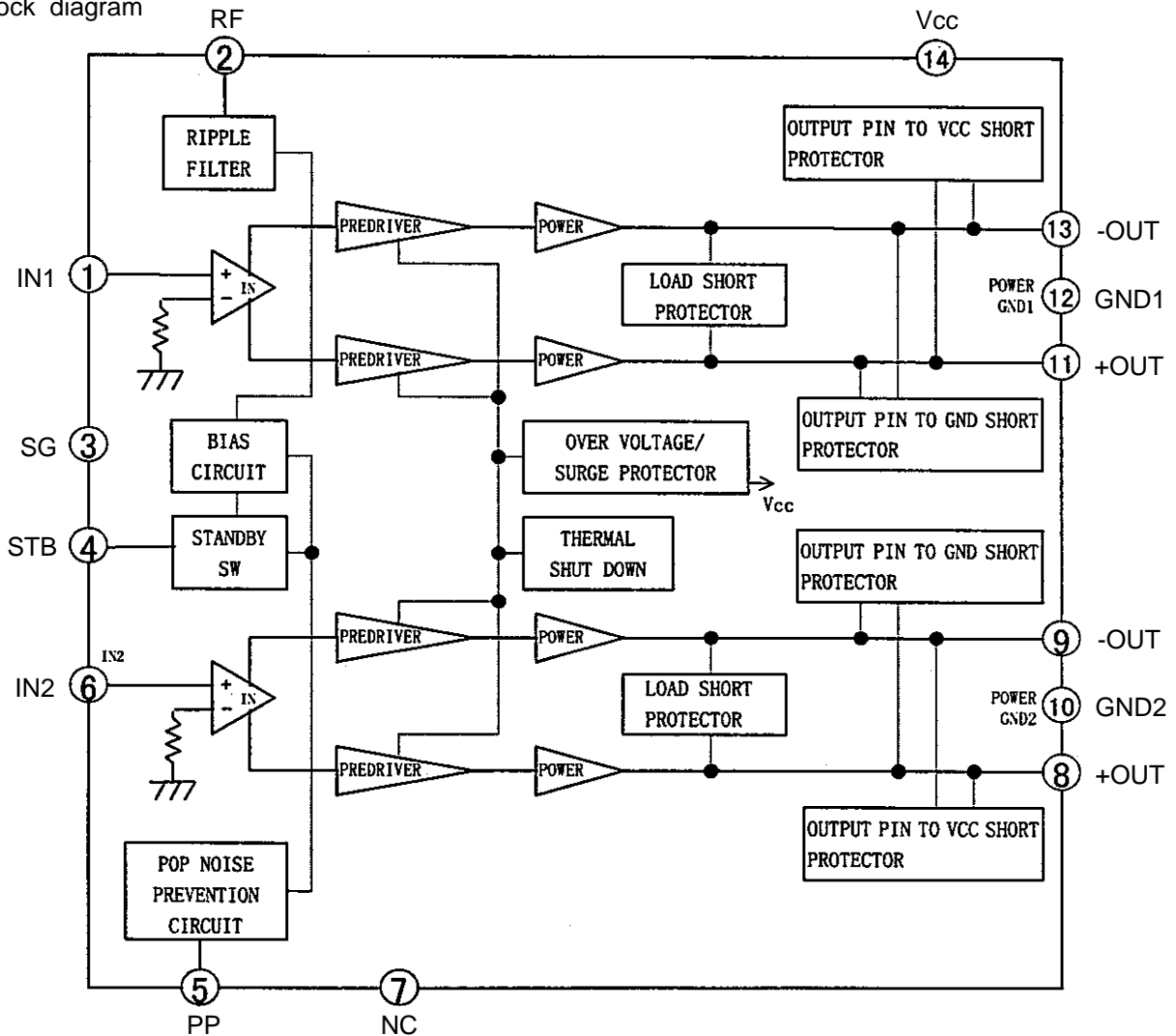

AN22000A(IC601):RF & SERVO AMP

1. Pin layout

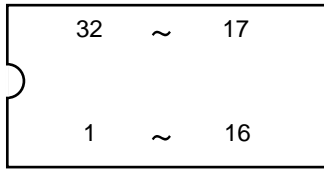

2. Block

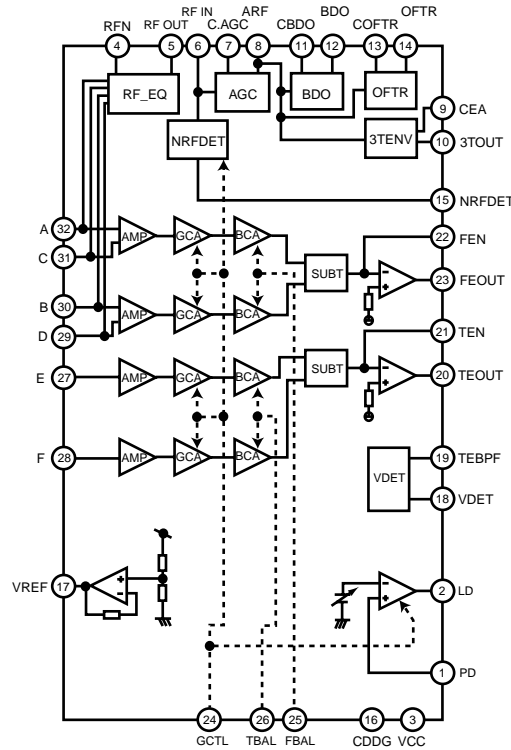

3. Function

Pin No.	Symbol	Function	Pin No.	Symbol	Function
1	PD	APC Amp. Input terminal	16	CDDG	Earth terminal
2	LD	APC Amp. Output terminal	17	VREF	VREF output terminal
3	VCC	Power supply terminal	18	VDET	VDET output terminal
4	RFN	RF addition Amp. Reversing input terminal	19	TEBPF	VDET input terminal
5	RF OUT	RF addition Amp. Output terminal	20	TEOUT	TE Amp. output terminal
6	RF IN	AGC input terminal	21	TEN	TE Amp. reversing input terminal
7	C.AGC	Terminal of connection of capacity of AGC loop filter.	22	FEN	FE Amp. reversing input terminal
8	ARF	AGC output terminal	23	FEOUT	FE Amp. output terminal
9	CEA	Capacity connection terminal for HPF-Amp.	24	GCTL	Terminal GCTL & APC
10	3TOUT	3TENV output terminal	25	FBAL	FBAL control terminal
11	CBDO	Capacity connection terminal for RF shade side envelope detection	26	TBAL	TBAL control terminal
12	BDO	BDO output terminal	27	E	Tracking signal input terminal 1
13	COFTR	Capacity connection terminal for RF discernment side envelope detection	28	F	Tracking signal input terminal 2
14	OFTR	OFTR output terminal	29	D	Focus signal input terminal 4
15	NRFDET	NRFDET output terminal	30	B	Focus signal input terminal 2
			31	C	Focus signal input terminal 3
			32	A	Focus signal input terminal 1

■ LA1838 (IC1): FM AM IF AMP&detector, FM MPX decoder

1. Block Diagram

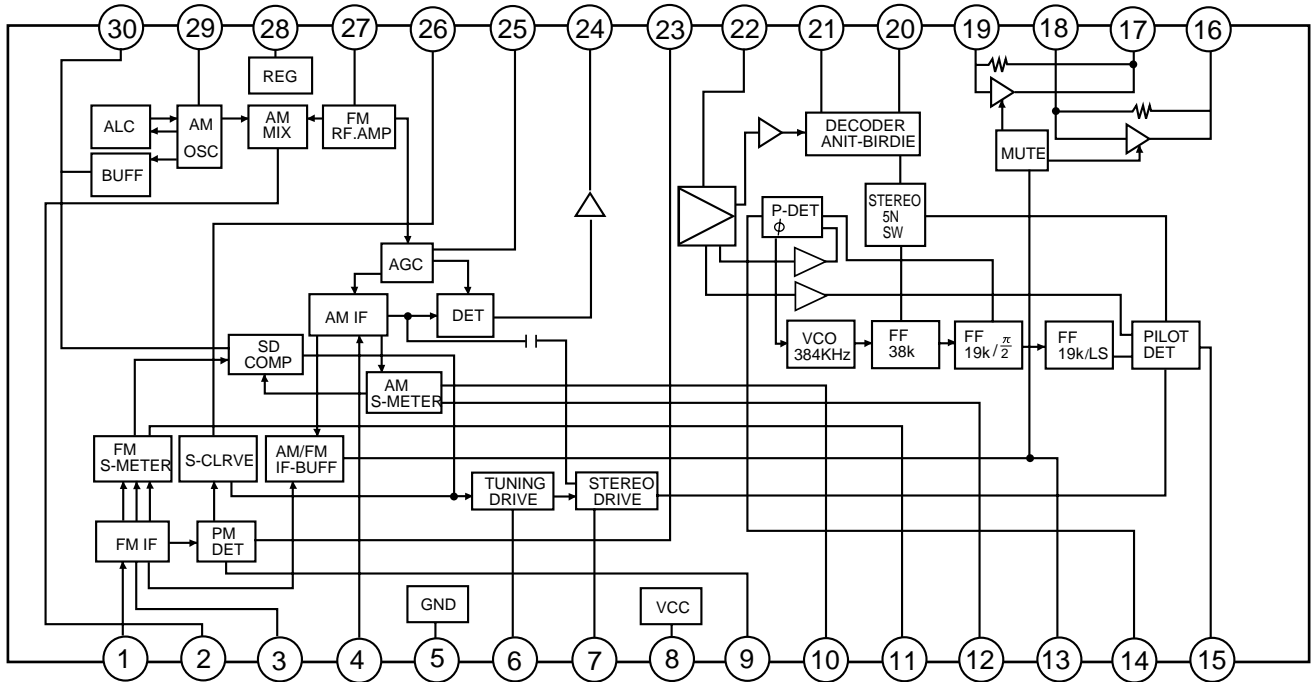

2. Pin Function

Pin No.	Symbol	I/O	Function	Pin No.	Symbol	I/O	Function
1	FM IN	I	This is an input terminal of FM IF signal.	16	L OUT	O	Left channel signal output.
2	AM MIX	O	This is an out put terminal for AM mixer.	17	R OUT	O	Right channel signal output.
3	FM IF	I	Bypass of FM IF	18	L IN	I	Input terminal of the left channel post AMP.
4	AM IF	I	Input of AM IF Signal.	19	R IN	I	Input terminal of the right channel post AMP.
5	GND	-	This is the device ground terminal.	20	RO	O	Mpx Right channel signal output.
6	TUNED	O	When the set is tuning, this terminal becomes "L".	21	LO	O	Mpx Left channel signal output.
7	STEREO	O	Stereo indicator output. Stereo "L", Mono: "H"	22	IF IN	I	Mpx input terminal
8	VCC	-	This is the power supply terminal.	23	FM OUT	O	FM detection output.
9	FM DET	-	FM detect transformer.	24	AM DET	O	AM detection output.
10	AM SD	-	This is a terminal of AM ceramic filter.	25	AM AGC	I	This is an AGC voltage input terminal for AM
11	FM VSM	O	Adjust FM SD sensitivity.	26	AFC	-	This is an output terminal of voltage for FM-AFC.
12	AM VSM	O	Adjust AM SD sensitivity.	27	AM RF	I	AM RF signal input.
13	MUTE	I/O	When the signal of IF REQ of IC121(LC72131) appear, the signal of FM/AM IF output. //Muting control input.	28	REG	O	Register value between pin 26 and pin28 desides the frequency width of the input signal.
14	FM/AM	I	Change over the FM/AM input. "H" :FM, "L" : AM	29	AM OSC	-	This is a terminal of AM Local oscillation circuit.
15	MONO/ST	O	Stereo : "H", Mono: "L"	30	OSC BUFFER	O	AM Local oscillation Signal output.

■ LC72136N (IC2) : PLL frequency synthesizer

1. Pin layout

XT	1	22	XT
FM/AM	2	21	GND
CE	3	20	LPFOUT
DI	4	19	LPFIN
CLOCK	5	18	PD
DO	6	17	VCC
FM/ST/VCO	7	16	FMIN
AM/FM	8	15	AMIN
	9	14	
	10	13	IFCONT
SDIN	11	12	IFIN

2. Block diagram

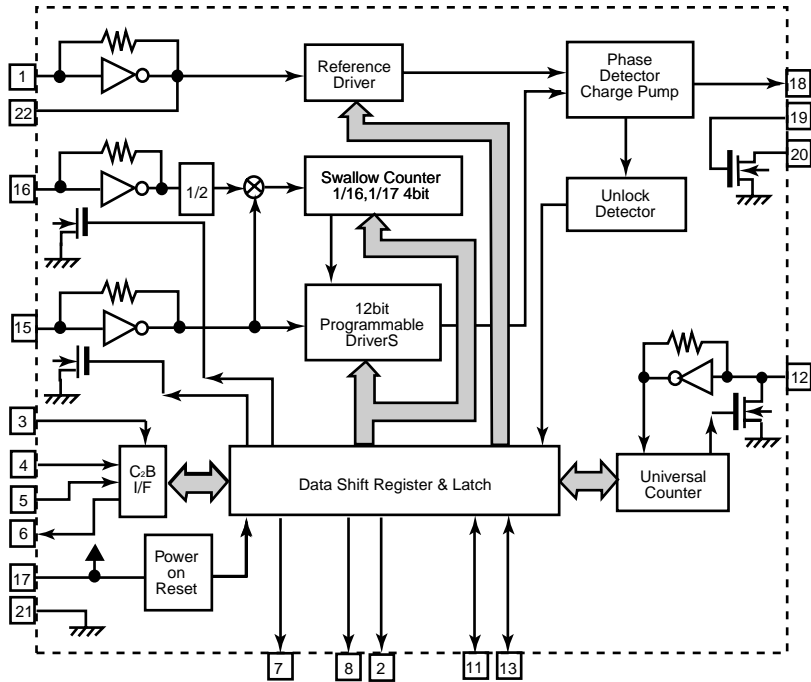

3. Pin function

Pin No.	Symbol	I/O	Function	Pin No.	Symbol	I/O	Function
1	XT	I	X'tal oscillator connect (75kHz)	12	IFIN	I	IF counter signal input
2	FM/AM	O	LOW:FM mode	13	IFCONT	O	IF signal output
3	CE	I	When data output/input for 4pin(input) and 6pin(output): H	14		-	Not use
4	DI	I	Input for receive the serial data from controller	15	AMIN	I	AM Local OSC signal output
5	CLOCK	I	Sync signal input use	16	FMIN	I	FM Local OSC signal input
6	DO	O	Data output for Controller Output port	17	VCC	-	Power supply(VDD=4.5-5.5V) When power ON:Reset circuit move
7	FM/ST/VCO	O	"Low": MW mode	18	PD	O	PLL charge pump output(H: Local OSC frequency Height than Reference frequency. L: Low Agreement: Height impedance)
8	AM/FM	O	Open state after the power on reset	19	LPFIN	I	Input for active lowpassfilter of PLL
9	LW	I/O	Input/output port	20	LPFOUT	O	Output for active lowpassfilter of PLL
10	MW	I/O	Input/output port	21	GND	-	Connected to GND
11	SDIN	I/O	Data input/output	22	XT	I	X'tal oscillator(75KHz)

■ LC72723(IC3):RDS

1. Pin Assignment

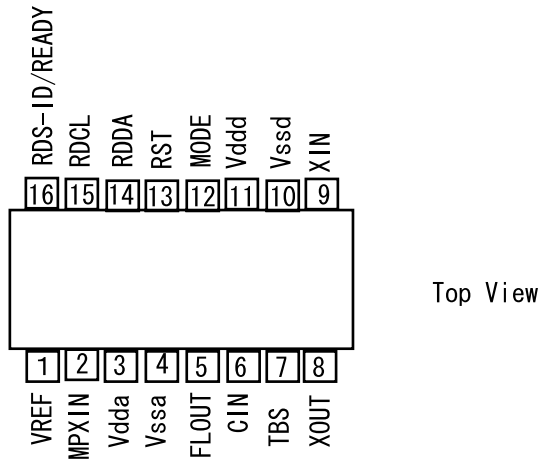

2. Block diagram

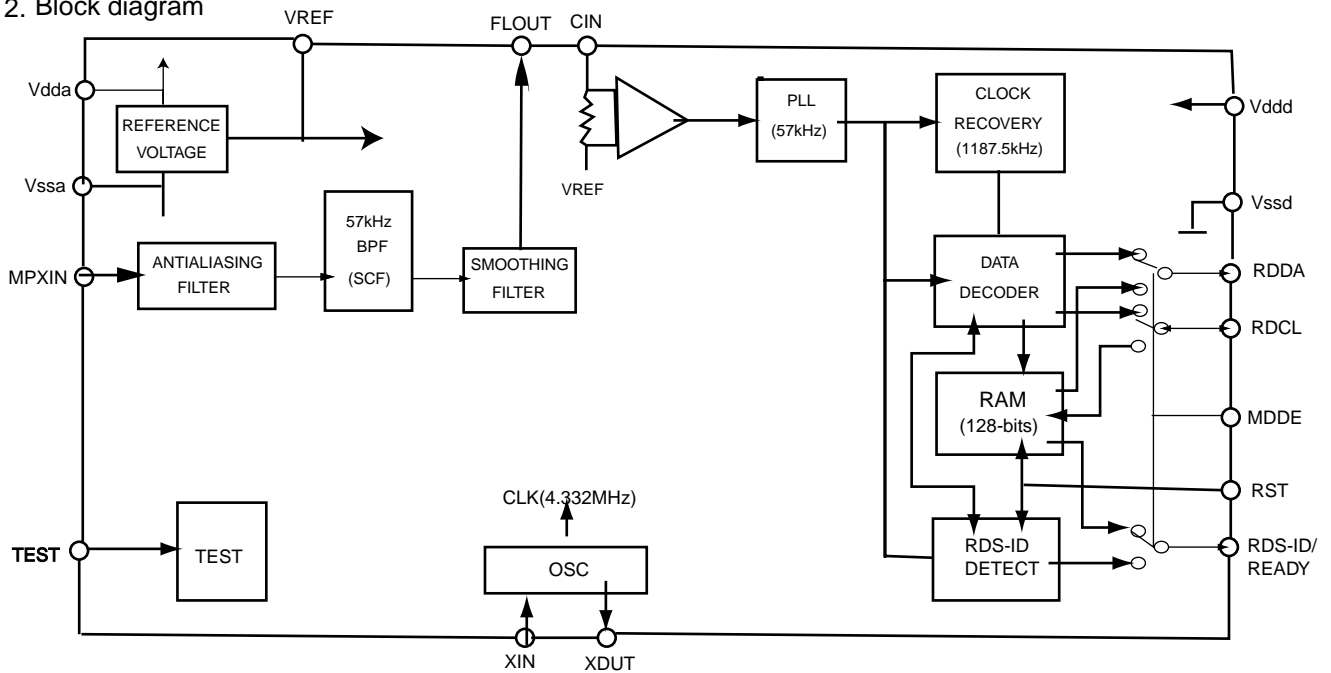

3. Pin functions

Pin No.	Symbol	I/O	Function
1	VREF	O	Reference voltage output (Vdda/2)
2	MPXIN	I	Baseband (multiplexed) signal input
3	Vdda	—	Analog power supply (+5V)
4	Vssa	—	Analog ground
5	FLOUT	O	Subcarrier input (filter output)
6	CIN	I	Subcarrier input (comparator input)
7	TEST	I	Test input
8	XOUT	O	Crystal oscillator output (4.332MHz)
9	XIN	I	Crystal oscillator input (external reference input)
10	Vssd	—	Digital ground
11	Vddd	—	Digital power supply
12	MODE	I	Read mode setting (0:master,1:slave)
13	RST	I	RDS-ID/RAM reset (positive polarity)
14	RDDA	O	RDS data output
15	RDCL	I/O	RDS clock output (master mode)/RDS clock input (slave mode)
16	RDS-ID READY	O	RDS-ID/READY output (negative polarity)

■ **LB1641 (IC802) : DC Motor driver**

1. Pin layout

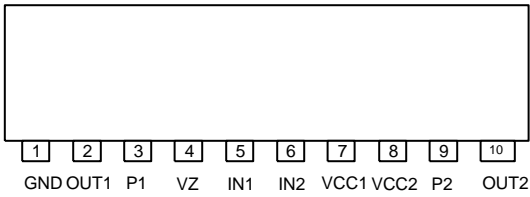

2. Pin function

Input		Output		Mode
IN1	IN2	OUT1	OUT2	
0	0	0	0	Brake
1	0	1	0	CLOCKWISE
0	1	0	1	COUNTER-CLOCKWISE
1	1	0	0	Brake

■ **BU4094BC(IC33):Serial to parallel port extension**

1.Pin layout

STROBE	1	16	Vdd
DATA	2	15	OUTPUT ENABLE
CLOCK	3	14	Q5
Q1	4	13	Q6
Q2	5	12	Q7
Q3	6	11	Q8
Q4	7	10	Q's
Vss	8	9	Qs

2.Block diagram

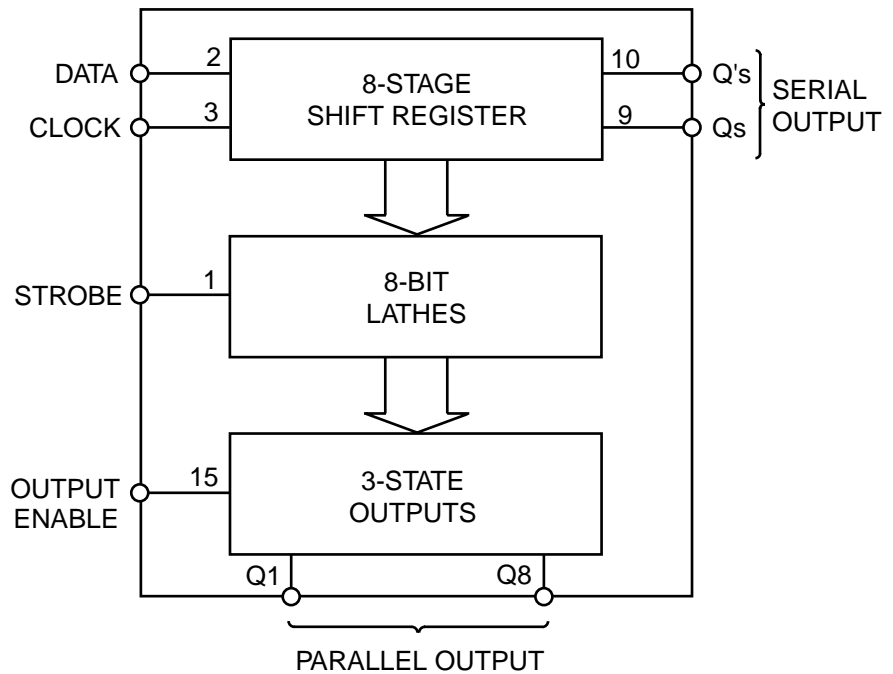

■ BA3126N(IC31) : R/P Switch

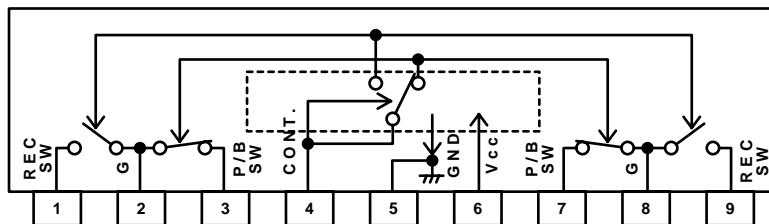

■ GP1U26X (IC933)

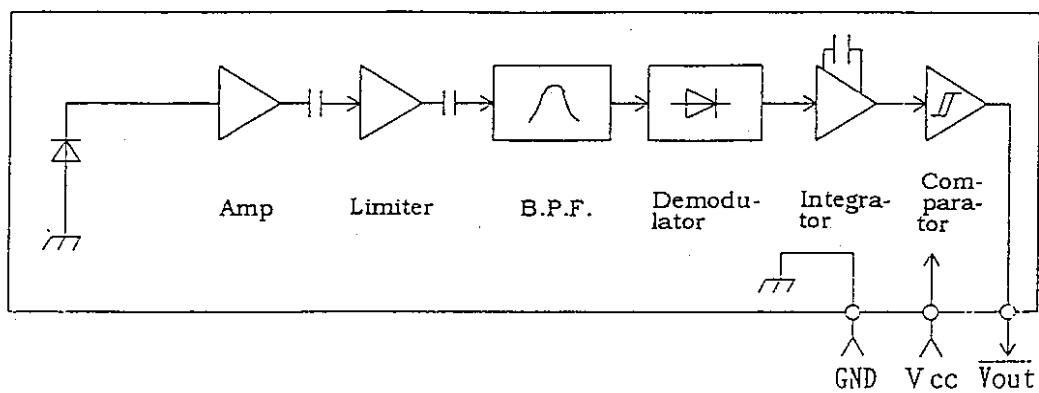

■ NJU6433FG1 (IC934)

1. Pin layout

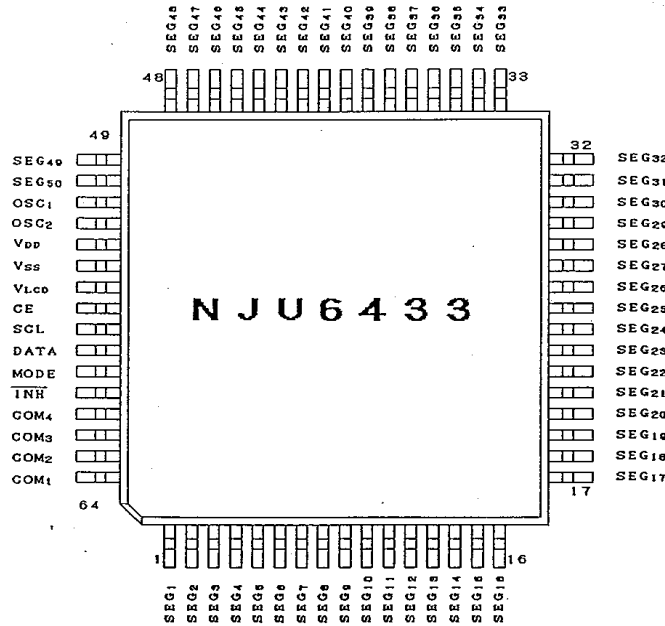

2. Block diagram

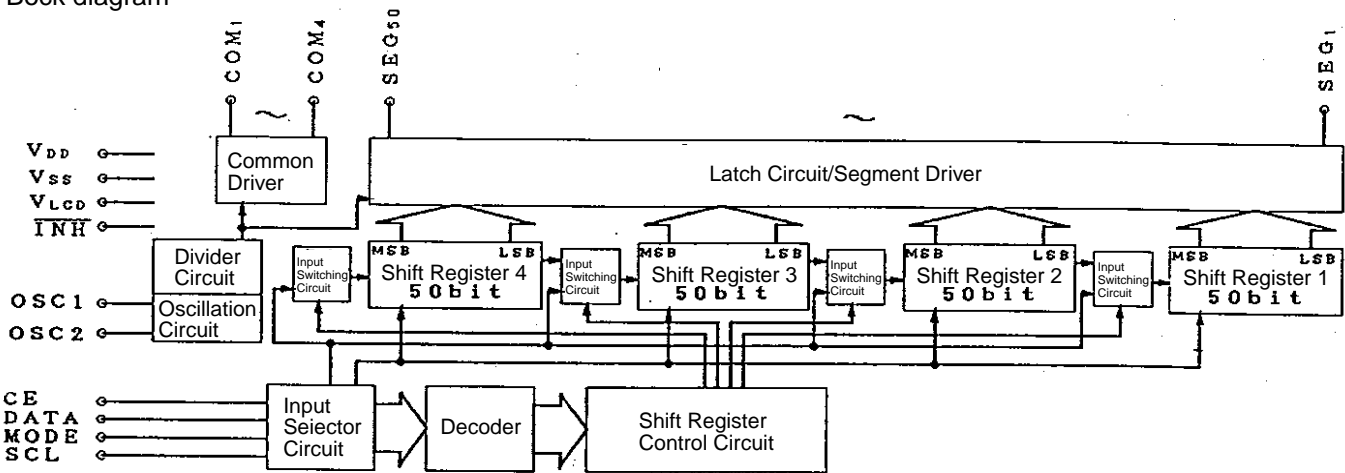

3. Pin function

Pin No.	Symbol	Pin No.	Symbol	Pin No.	Symbol	Pin No.	Symbol
1	SEG ₁	17	SEG ₁₇	33	SEG ₃₃	49	SEG ₄₉
2	SEG ₂	18	SEG ₁₈	34	SEG ₃₄	50	SEG ₅₀
3	SEG ₃	19	SEG ₁₉	35	SEG ₃₅	51	OSC ₁
4	SEG ₄	20	SEG ₂₀	36	SEG ₃₆	52	OSC ₂
5	SEG ₅	21	SEG ₂₁	37	SEG ₃₇	53	V _{DD}
6	SEG ₆	22	SEG ₂₂	38	SEG ₃₈	54	V _{SS}
7	SEG ₇	23	SEG ₂₃	39	SEG ₃₉	55	V _{LCD}
8	SEG ₈	24	SEG ₂₄	40	SEG ₄₀	56	CE
9	SEG ₉	25	SEG ₂₅	41	SEG ₄₁	57	SCL
10	SEG ₁₀	26	SEG ₂₆	42	SEG ₄₂	58	DATA
11	SEG ₁₁	27	SEG ₂₇	43	SEG ₄₃	59	MODE
12	SEG ₁₂	28	SEG ₂₈	44	SEG ₄₄	60	INH
13	SEG ₁₃	29	SEG ₂₉	45	SEG ₄₅	61	COM ₄
14	SEG ₁₄	30	SEG ₃₀	46	SEG ₄₆	62	COM ₃
15	SEG ₁₅	31	SEG ₃₁	47	SEG ₄₇	63	COM ₂
16	SEG ₁₆	32	SEG ₃₂	48	SEG ₄₈	64	COM ₁

■ LC75345M (IC901)

1. Pin layout

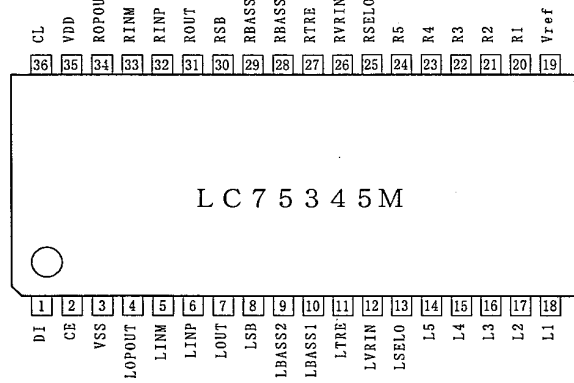

2. Block Diagram

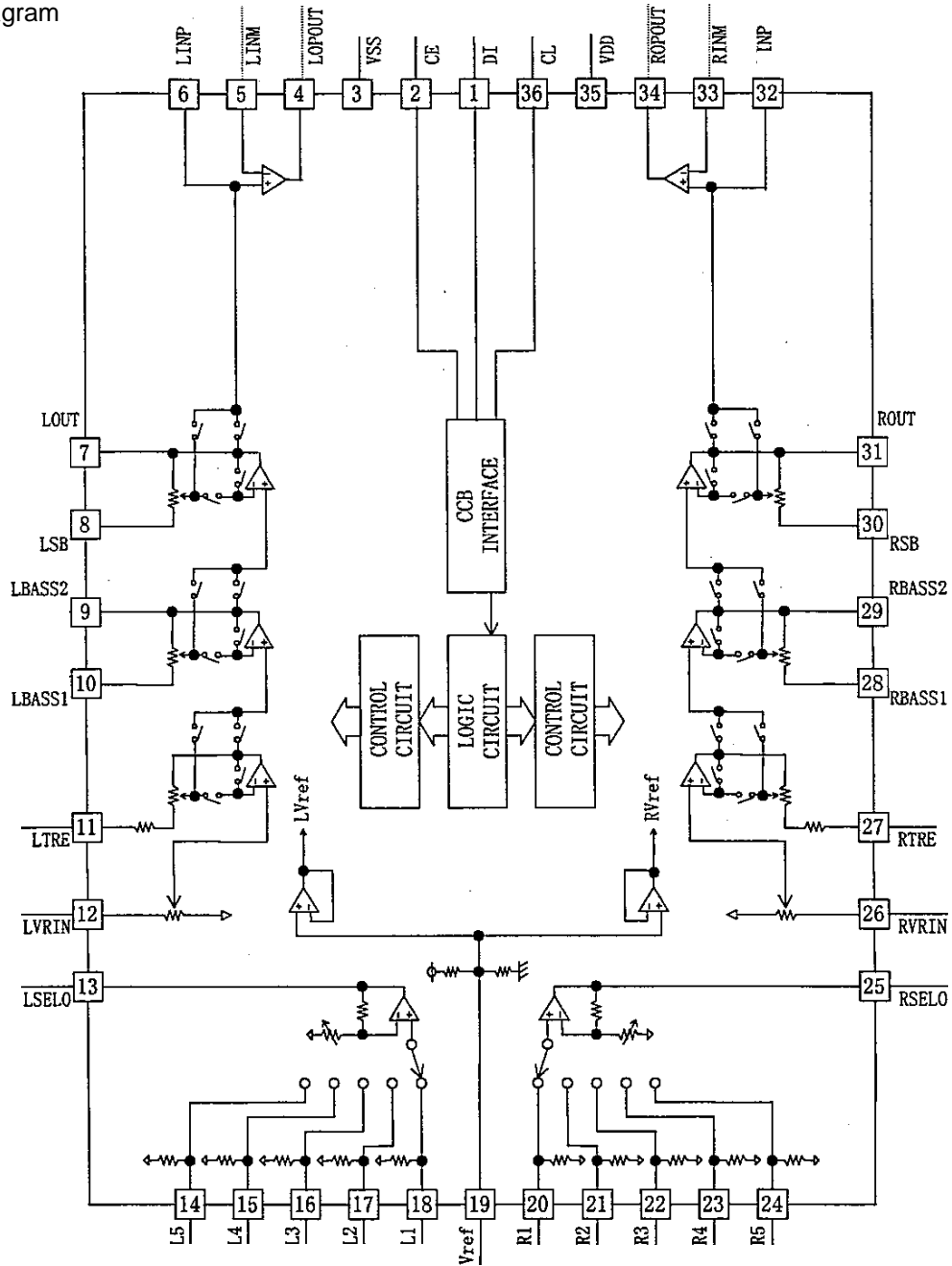

3. Descriptions

Pin name	Pin No.	Descriptions
L1 L2 L3 L4 L5 R1 R2 R3 R4 R5	18 17 16 15 14 20 21 22 23 24	Input signal pin
LSEL0 RSEL0	13 25	Input selector output pin.
LBASS1 LBASS2 RBASS1 RBASS2 LSB RSB	10 9 28 29 8 30	Capacitor and resistor connection pins comprising filters for bass and super-bass band.
LOUT ROUT	7 31	ATT + equalizer output pin/capacitor connection pin comprising filter for super-bass
LVRIN RVRIN	12 26	Volume input pin
LTRE RTRE	11 27	Capacitor connection pin comprising treble band filter.

Pin name	Pin No.	Descriptions
Vref	19	0.5 × VDD voltage generation block for analog ground. Capacitor of several 10 μF to be connected between Vref and AWSS (VSS) as a counter-measure against power ripple.
VSS	3	Ground pin
VDD	35	Supply pin
CE	2	Chip enable pin. Data written into an internal latch in a timing of [H] → [L]. Each analog switch is activated. Data transfer enabled at [H] level.
DI CL	1 36	Serial data and clock input pin for control.
LINP RINP	6 32	Non-inverted input pin of general-purpose operation amplifier. Keep this pin open when not used.
LINM RINM	5 33	Non-inverted input pin of general-purpose operation amplifier. Connect to L (R) OPOUT pin when not used. (Connect between pins 5 and 4) (Connect between pins 33 and 34)
LOPOUT ROPOUT	4 34	Output pin of general-purpose operation amplifier. Connect to L (R) INN pin when not used. (Connect between pins 5 and 4) (Connect between pins 33 and 34)

■ AN7317 (IC32) : PB/REC amp

Block Diagram

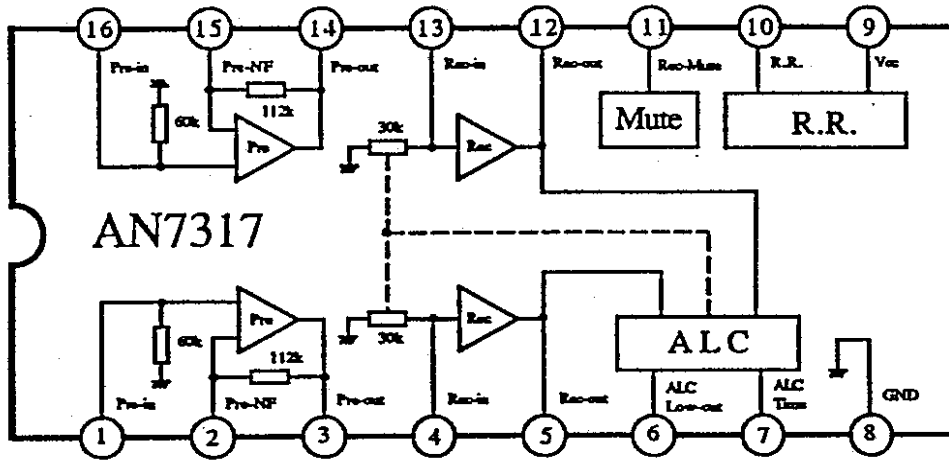

Pin Descriptions

Pin No.	Pin Descriptions
1	Channel 1 Playback Amplifier Input
2	Channel 1 Playback Amplifier Negative Feedback
3	Channel 1 Playback Amplifier Output
4	Channel 1 Record Amplifier Input
5	Channel 1 Record Amplifier Output
6	ALC Low-Cut
7	ALC Time
8	Ground
9	Vcc
10.	Ripple Filter
11	Record - Amplifier Mute
12	Channel 2 Record Amplifier Output
13	Channel 2 Record Amplifier Input
14	Channel 2 Playback Amplifier Output
15	Channel 2 Playback Amplifier Negative Feedback
16	Channel 2 Playback Amplifier Input

Internal connection of display

■ QLD0160-001 (D1934)

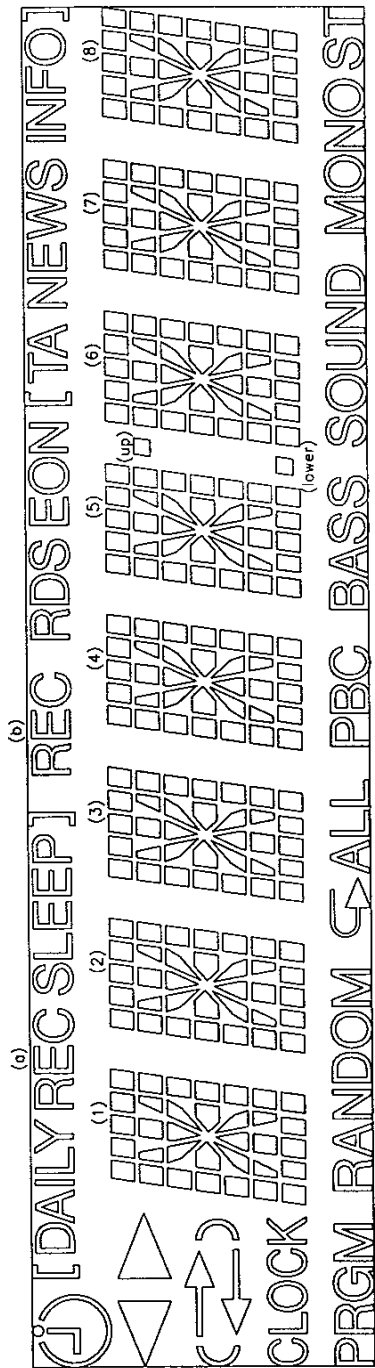
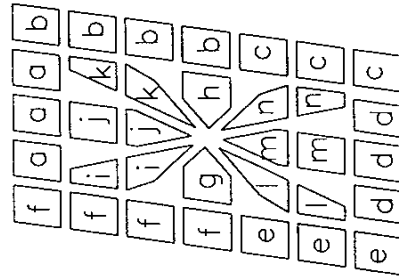

PIN NO.	1	2	3	4	5	6	7	8	9	10	11	12	13	14	15	16	17	18	19	20	21	22	23	24	25	26	27	28	29	30	31	32	33	34	35	36	37	38	39	40		
	COM0				[] (over) right	CLOCK			1l 1m 1d	1e 1g 1n 1c	1f 1i 1j	1h 2f 2i	1a 1k 1b	2a	2d	3l 3m	3d	ALL	4l 4m	4d	PBC	5l 5m	5d	BASS	6l 6m	6d	BOUND	7l 7m	7d	MONG	8l 8m	8d	ST									
		COM1			PRGM				1e 1g 1n 1c	1f 1i 1j	1h 2f 2i	1a 1k 1b	2a	2d	3l 3m	3d	ALL	4l 4m	4d	PBC	5l 5m	5d	BASS	6l 6m	6d	BOUND	7l 7m	7d	MONG	8l 8m	8d	ST										
			COM2			(up)			1e 1g 1n 1c	1f 1i 1j	1h 2f 2i	1a 1k 1b	2a	2d	3l 3m	3d	ALL	4l 4m	4d	PBC	5l 5m	5d	BASS	6l 6m	6d	BOUND	7l 7m	7d	MONG	8l 8m	8d	ST										
				COM3	INFO			DAILY	REC (a)	1a 1k 1b	SLEEP	2a	2k 2b	3a	3k 3b	REC (b)	4a	4k 4b	RDS	5a	5k 5b	EON	6a	6k 6b	TA	7a	7k 7b	NEWS	8a	8k 8b												

<<MEMO>>

JVC

VICTOR COMPANY OF JAPAN, LIMITED

AUDIO & COMMUNICATION BUSINESS DIVISION

PERSONAL & MOBILE NETWORK BUSINESS UNIT 10-1,1Chome,Ohwatari-machi,Maebashi-city,371-8543,Japan